

**risen**

# User Manual

**eFlex 836kWh Liquid-Cooled ESS  
SU836E418KM**

Version

02

Release Date

Dec. 2, 2025





**Copyright © SYL (Ningbo) Battery Co., Ltd. 2025. All Rights Reserved.**

Without prior written authorization from SYL (Ningbo) Battery Co., Ltd., any entity or individual is strictly prohibited from transmitting, disseminating, or distributing any portion or entirety of this document to any third party, organization, or online platform through any means, including but not limited to reproduction, redistribution, adaptation, citation, and any other derivative forms.

## Trademarks

**risen** and other “Risen Storage” and “SYL” trademarks that may appear in this manual are owned by SYL (Ningbo) Battery Co., Ltd. All other trademarks or registered trademarks mentioned in this manual are owned by their respective owners.

## Important Notes

Retain this manual in an easily accessible location for immediate reference during product operation or maintenance. While we make every effort to ensure the accuracy of this manual, both the product and documentation are subject to continuous improvement and updates. Should there be any discrepancies between the descriptions/illustrations herein and the physical product, the actual device specifications shall prevail.

## About This Manual

---

### Overview

This manual is specifically compiled for SYL BESS products. It contains key content such as important safety precautions, product introduction, transportation and storage, product installation, electrical connections, system commissioning, system maintenance, and system troubleshooting. These contents will provide clear guidance and strong guarantees for your installation and use, helping to prevent installation failures or subsequent malfunctions caused by improper operation or neglect of critical details.

Please ensure that you read this manual thoroughly and carefully before performing any practical operations. If you have any questions about the content provided in this manual, feel free to contact SYL for consultation at any time. We will do our best to answer your questions. For contact information, please refer to Chapter [9 Technical Support and After-Sales Service](#).

### Target Group

This manual is applicable to product sales engineers, technical support engineers, and operators of energy storage systems. All installation and usage operations must be

performed solely by qualified technical personnel. Qualified technical personnel must meet the following requirements:

- Have received specialized training, are familiar with relevant safety regulations of electrical systems, and possess the necessary knowledge and practical experience for performing related operations.
- Have read this manual thoroughly and carefully, are familiar with specific operational procedures, and have mastered relevant safety precautions.
- Have knowledge of relevant laws, regulations, and industry standards in the country or region where the project is located.

## Symbol Explanations

This manual may contain the following symbols, which represent the following meanings:

### **DANGER**

Indicates an imminently hazardous situation which, if not avoided, will result in death or serious personal injury.

### **WARNING**

Indicates a moderately hazardous situation which, if not avoided, could result in death or serious personal injury.

## CAUTION

Indicates a slightly hazardous situation which, if not avoided, may result in minor or moderate personal injury.

## NOTICE

Indicates a potential risk which, if not avoided, may lead to equipment malfunction or property damage.

## NOTE

Used to emphasize key points or provide supplementary explanations.

 **Note:** Used to provide additional explanations for specific sections.

Underline: Indicates hyperlinked content that allows users to click and quickly navigate to relevant sections or directly access designated website pages.

## Revision Record

### **Version 01 (2025-09-18)-Jinglei Guo**

First official release.

### **Version 02 (2025-11-15)-James Ge**

1. Adjust the product schematic diagrams in each field to the latest version.
2. In the "6.1 Precautions", add the following description: When the product is placed for a long time without formal operation, auxiliary power should be supplied to ensure that the temperature - control and dehumidification equipment (such as liquid - cooled units, air - cooled air conditioners, heaters, dehumidifiers, etc.) operates normally, so as to ensure that the temperature and humidity inside the box meet the requirements, remain dry, and there is no accumulated water.
3. In 6.2.1, add the description of disconnection of the FFS start - up wire.
4. In 6.2.2, change "Ensure that the liquid cooling unit..." to "Ensure that the liquid cooling pipeline...".
5. In 6.3, revise the auxiliary power connection diagram to the latest version.
6. In 7.3 Fire Protection System Maintenance, add the precautions for the wiring of the fire - extinguishing device.
7. In "8.3.1 Abnormal System Data Display", add the content: Reproduction of short - board cells.
8. In 9, the after - sales email address is changed from [essmkt@risenstorage.com](mailto:essmkt@risenstorage.com) to [service@syllbattery.com](mailto:service@syllbattery.com).

9. 5.5.2 In the connection of DC power cables, the tightening torque is adjusted from "20.83 - 24.50 N·m" to "12 ± 0.5 N·m", and the schematic diagram should be adjusted accordingly.
10. 5.5.3 In the connection of PCS power cables, adjust the bolt model and tightening torque data. Add the recommended cable diameter of 500 kcmil, and adjust the schematic diagram.
11. 5.5.4 Adjust the terminal correspondence table and the schematic diagram.
12. 5.5.6 Adjust the schematic diagram.
13. 6.3.1 Adjust the schematic diagram in the auxiliary power connection diagram.
14. 6.3.2 Adjust the description of controlled objects.
15. 6.3.3 In the 12th description of the auxiliary power supply, change "MCB12" to "MCB23".
16. 6.3.6 In the 2nd description of turning off the auxiliary power supply, change "MCB12" to "MCB23".

# Table of Contents

---

Copyright.....	i
About This Manual .....	ii
Table of Contents.....	vii
<b>1 Safety Precautions.....</b>	<b>1</b>
1.1 Declaration .....	1
1.2 General Safety.....	2
1.3 Personnel Safety.....	4
1.4 Electrical Safety .....	5
1.5 Battery Safety .....	8
1.6 Handling, Transportation, and Storage Safety.....	17
1.7 Maintenance and Replacement.....	17
<b>2 Product Introduction .....</b>	<b>20</b>
2.1 Product Information .....	20
2.2 Product Design .....	24
2.2.1 Product Appearance.....	24
2.2.2 Product Markings .....	27
2.3 Key Components .....	31

2.3.1	Battery.....	31
2.3.2	Battery Management System (BMS) .....	34
2.3.3	Golden Shield .....	36
2.4	Fire Suppression System .....	38
2.4.1	Precautions.....	38
2.4.2	Fire Suppression System Overview .....	39
2.4.3	Fire Suppression System Components .....	39
2.4.4	Fire Suppression System Logic Diagram.....	41
2.4.5	Water Supply for Water-Based Fire Suppression System.....	41
2.4.6	Post-Discharge Handling Measures for Aerosol Fire Suppression System...42	
2.5	Thermal Management System .....	45
2.5.1	Precautions.....	45
2.5.2	Battery Cabinet Liquid Cooling Unit.....	45
2.5.3	BCP Cabinet HVAC.....	46
3	Transportation and Storage .....	50
3.1	Handling and Transportation.....	50
3.1.1	Precautions.....	50
3.1.2	Handling .....	51
3.1.3	Transportation .....	52
3.2	Storage.....	53
3.2.1	Precautions.....	53

3.2.2	Storage Requirements .....	54
<b>4</b>	<b>Product Installation.....</b>	<b>55</b>
4.1	Precautions.....	55
4.2	Pre-Installation Inspection .....	55
4.2.1	Outer Packaging Inspection.....	55
4.2.2	Delivered Items Inspection .....	56
4.3	Pre-Installation Preparation .....	56
4.3.1	Tools and Instruments.....	56
4.3.2	Personal Protective Equipment .....	58
4.4	Installation Requirements.....	58
4.4.1	Installation Environment Requirements.....	58
4.4.2	Installation Foundation Requirements.....	60
4.4.3	Installation Space Requirements.....	61
4.5	Equipment Installation .....	62
4.5.1	Equipment Handling .....	62
4.5.2	Equipment Fixing.....	64
4.5.3	Equipment Grounding .....	66
4.5.4	Wiring and Sealing .....	67
4.6	Post-Installation Inspection.....	68
<b>5</b>	<b>Electrical Connection.....</b>	<b>69</b>
5.1	Precautions.....	69

5.2	Pre-Connection Inspection .....	70
5.3	Pre-Connection Preparation.....	70
5.3.1	Tools and Instruments.....	70
5.3.2	Personal Protective Equipment .....	72
5.4	Battery Cabinet Electrical Connections.....	73
5.4.1	Panel and Functions .....	73
5.5	BCP Cabinet Electrical Connections.....	76
5.5.1	BCP Cabinet Auxiliary Power Supply Cable Connection .....	76
5.5.2	DC Power Cable Connection .....	76
5.5.3	PCS Power Cable Connection.....	77
5.5.4	Battery Cabinet Auxiliary Power Supply Cables and Communication Cables Connection .....	78
5.5.5	Ethernet Communication Port Connection.....	79
5.5.6	Reserved Dry Contact Interfaces.....	80
5.6	MSD Installation.....	82
5.7	Post-Connection Inspection .....	83
6	System Commissioning.....	84
6.1	Precautions.....	84
6.2	Pre-Commissioning Inspection.....	85
6.2.1	Cable Connection.....	85
6.2.2	System Setup.....	85

<b>6.3</b>	<b>Power-On Commissioning</b> .....	<b>86</b>
6.3.1	Wiring Diagram for Auxiliary Power Supply .....	86
6.3.2	Circuit Breakers and Control Objects.....	86
6.3.3	Auxiliary Power Supply.....	87
6.3.4	Operational Status Overview .....	89
6.3.5	High-Voltage DC Power On/Off Operations .....	90
6.3.6	Powering Off the Auxiliary Power Supply .....	92
<b>7</b>	<b>System Maintenance</b> .....	<b>93</b>
7.1	Precautions.....	93
7.2	Battery System Maintenance.....	95
7.2.1	Precautions.....	95
7.2.2	Tools and Instruments .....	97
7.2.3	Personal Protective Equipment .....	99
7.2.4	Terminology .....	100
7.2.5	Maintenance Requirements .....	101
7.2.6	Inspection Items .....	103
7.2.7	Abnormal Condition Handling .....	103
7.2.8	Pre-Maintenance Checks .....	106
7.2.9	Charge-Discharge Activation .....	106
7.2.10	Voltage Balancing.....	107
7.2.11	SOC Calibration.....	112

<b>7.3</b>	<b>Fire Suppression System Maintenance .....</b>	<b>113</b>
7.3.1	Tools and Instruments .....	114
7.3.2	Maintenance Items.....	115
<b>7.4</b>	<b>Thermal Management System Maintenance .....</b>	<b>117</b>
7.4.1	Tools and Instruments .....	117
7.4.2	Daily Maintenance.....	119
7.4.3	Regular Maintenance .....	120
<b>7.5</b>	<b>Cabinet Maintenance.....</b>	<b>127</b>
7.5.1	Tools and Instruments.....	127
7.5.2	Maintenance Items.....	128
<b>7.6</b>	<b>UPS Maintenance .....</b>	<b>130</b>
7.6.1	Tools and Instruments .....	130
7.6.2	Maintenance Requirements .....	131
<b>8</b>	<b>Troubleshooting .....</b>	<b>133</b>
8.1	Precautions.....	133
8.2	Logging Fault Information.....	134
<b>8.3</b>	<b>Common Fault Troubleshooting and Solutions .....</b>	<b>135</b>
8.3.1	Abnormal System Data Display .....	135
8.3.2	Communication Fault.....	139
8.3.3	Fire Suppression System Fault.....	141
8.3.4	Liquid Cooling System Fault .....	141

8.3.5	HVAC Fault .....	145
8.3.6	UPS Fault.....	148
8.3.7	Other Faults.....	151
<b>9</b>	<b>Technical Support and After-Sales Service.....</b>	<b>153</b>
	<b>Contact Information .....</b>	<b>153</b>
	<b>Warranty.....</b>	<b>153</b>
	<b>Feedback.....</b>	<b>155</b>
	<b>Appendix .....</b>	<b>156</b>
	<b>Abbreviations.....</b>	<b>156</b>
	<b>Fastening Torque.....</b>	<b>158</b>

# 1 Safety Precautions

---

## 1.1 Declaration

Before installing, operating, or maintaining the equipment, read this manual thoroughly and follow all safety precautions indicated on the equipment and in this manual.

When installing, operating, or maintaining the equipment, comply with local laws, regulations, and standards. The safety precautions in this manual are provided solely as a supplement to local laws, regulations, and standards.

The 'DANGER', 'WARNING', 'CAUTION', 'NOTICE', and 'NOTE' statements in this manual do not represent all safety requirements that must be followed and are provided solely as a supplement to all safety precautions. SYL assumes no liability for any damages resulting from failure to follow safety operation requirements or violation of safety standards for equipment design, production, and use.

## 1.2 General Safety

### **DANGER**

- It is strictly prohibited to install, operate, or handle outdoor equipment and cables under adverse weather conditions such as lightning, rain, snow, or level 6 strong winds, including but not limited to activities such as equipment transportation, equipment/cable operation, plugging/unplugging signal ports connected to outdoor equipment, high-altitude operations, and outdoor installation.
- In case of a fire, immediately evacuate the building or equipment area, activate the fire alarm, and call the fire emergency number. Under no circumstances should you re-enter the burning building.

### **WARNING**

- Before touching any conductor surfaces or terminals, measure the voltage at the contact points to verify no risk of electric shock.
- Strictly prohibited to perform installation, wiring, maintenance, or replacement on energized equipment.
- Strictly prohibited to make unauthorized alterations to the equipment's structure or installation sequence under any circumstances.

## CAUTION

- Comply with the requirements of this manual, use appropriate tools, and properly operate them.

## NOTICE

- When performing operations such as transportation, transfer, installation, wiring, and maintenance, you must comply with the laws, regulations, and relevant standards of the country and region where the operations take place.
- Permission from the local power department of the country and region must be obtained before grid-connection work can be carried out.
- You should be fully familiar with the composition and working principle of the entire energy storage system, as well as the relevant standards of the country and region where the project is located.
- In case of paint scratches during the transportation and installation of the equipment, timely repairs must be made to prevent the scratched parts from being exposed to the outdoor environment for a long time.

## NOTE

- It is strictly prohibited to conduct reverse engineering, decompilation, disassembly, disassembly (in the software-related sense), adaptation,

implantation, or other derivative operations on the equipment software.

- It is forbidden to study the internal implementation of the equipment, obtain the source code of the equipment software, steal intellectual property rights, etc. in any way.
- Do not disclose the results of any equipment software performance tests.

## 1.3 Personnel Safety

### NOTICE

- Personnel responsible for installing and maintaining the equipment must undergo rigorous training, understand all safety precautions, master correct operating methods, and possess the knowledge and experience required to operate the relevant equipment.
- Only qualified professionals or trained personnel are permitted to install, operate, and maintain the equipment.
- Only qualified professionals are allowed to remove safety devices and conduct maintenance on the equipment.
- Personnel operating the equipment, including operators, trained personnel, and professionals, must possess the special operation qualifications required by the country and region where the project is located, such as high-voltage operation, working at heights, and special equipment operation

qualifications.

- Replacement of the equipment and its components, including software, must be carried out by professionals or authorized personnel.

**i Note:**

- **Qualified professionals:** Individuals who have received training or possess experience in equipment operation, and are fully aware of potential hazard sources and the degree of hazard severity during equipment installation, operation, and maintenance.
- **Trained personnel:** Individuals who have undergone relevant technical training and have necessary experience, can recognize hazards posed by specific operations, and take measures to minimize risks to themselves or others.
- **Operators:** Personnel who may come into contact with the equipment, excluding trained personnel and qualified professionals.

## 1.4 Electrical Safety

### General Requirements

 **WARNING**

Before making electrical connections, ensure the equipment is undamaged.

Failure to do so may result in electric shock or fire.

- All electrical connections must comply with the electrical standards of the country and region where the equipment is located.
- Permission from the local power department of the country and region must be obtained before grid-connected power generation can be carried out.
- Cables provided by the user should meet the requirements of local laws and regulations.
- When performing high-voltage operations, please use dedicated insulated tools.

## Grounding Requirements

- For equipment that requires grounding, the protective grounding wire must be installed first during installation and removed last when disassembling the equipment.
- It is prohibited to damage the grounding conductor.
- Do not operate the equipment without the grounding conductor installed.
- Equipment shall be provided with permanent protective grounding. Before operating the equipment, check its electrical connections to ensure the equipment is reliably grounded.

## DC Operation

### **WARNING**

It is prohibited to install or remove the power cable with the power on. When the power cable core comes into contact with the conductor, arcs or sparks will be generated, which may lead to fire or personal injury.

- Before making electrical connections to the equipment, if there is a possibility of coming

into contact with live parts, the corresponding disconnection device at the previous stage of the equipment must be switched off.

- Before connecting the power cord, make sure to confirm that the labels and markings on the power cable are correct, and then proceed with the connection.
- If the equipment has multiple inputs, all inputs of the equipment should be disconnected.

You can only operate the equipment after the equipment is completely powered off.

## Wiring Requirements

- Using cables in high-temperature environments may cause aging and damage to the insulation layer. The distance between the cables and the periphery of heat-generating devices or heat source areas should be at least 50 mm.
- Cables of the same type should be bundled together. Cables of different types should be laid at least 30 mm apart. It is prohibited to wind or cross them with each other.
- Cables must be firmly connected, have good insulation, and be of appropriate specifications.
- At the positions where cables pass through pipes or wire holes, protection measures must be taken to prevent the cables from being damaged by sharp edges, burrs, etc.

## Anti-static requirements

 **NOTICE**

The static electricity carried by the human body may cause irreversible damage to

electrostatically sensitive components on the single board of the energy storage system, such as large-scale integrated circuits (LSI). Therefore, when touching the PCB board, you must wear anti-static equipment throughout the process, such as anti-static gloves and anti-static wristbands. At the same time, it is strictly prohibited to wear clothing that easily generates static electricity, such as clothing made of acrylic or chemical fiber materials, to ensure the stable operation of the system and the safety of the components.

## 1.5 Battery Safety

### Declaration

SYL shall not be liable for equipment malfunctions, component damage, personal safety accidents, property damage, etc., caused by the following reasons:

- Damage to the battery, such as capacity loss or irreversible damage, caused by the user's failure to charge in a timely manner resulting in overdue storage.
- Battery damage, drops, leakage, etc., caused by improper operation or failure to connect the battery as required.
- Damage caused by over-discharge of the battery due to the customer's failure to power on in a timely manner after on-site installation and system connection.
- User's failure to properly set the battery operation management parameters.
- If the user or a third-party changes the battery usage scenario without informing our company. For example, connecting additional loads to the battery on their own, or mixing

the batteries provided by our company with other batteries, including but not limited to: mixing with batteries of other brands, mixing with batteries of different rated capacities, etc.

- Direct damage to the battery caused by the fact that the on-site equipment operating environment or external power parameters cannot meet the environmental requirements for normal operation. This includes the actual operating temperature of the battery being too high or too low, and the unstable power grid situation with frequent power outages.
- Abuse of the battery system, including but not limited to exceeding the rated current rate during operation and forced charging at low temperatures.
- The user does not properly maintain the battery in accordance with the maintenance manual.
- The battery gets stolen.
- The battery has gone beyond the warranty period.

## Basic Requirements

### DANGER

- Do not expose the battery to high-temperature environments or around heat-generating equipment such as open flames and transformers. Overheating of the battery may cause fire or explosion.
- Do not disassemble, modify, or damage the battery (e.g., inserting foreign objects, immersing in water or other liquids) to prevent battery short circuits, fires, or explosions.
- The battery energy storage system has a high fire risk. Before performing

battery operations, the following safety risks must be fully considered:

- The battery electrolyte is flammable, toxic, and volatile.
- Battery thermal runaway can generate various flammable and harmful gases.
- The accumulation of flammable gases produced after battery thermal runaway poses a risk of fire and explosion.

- Batteries should be stored independently within their original packaging. Avoid storing them together with other items, leaving them exposed to the open air, or stacking them to excessive heights.
- Batteries that have gone past their warranty period are not allowed to be used anymore.
- Under normal circumstances, do not take off the battery's original packaging. In case the battery needs to be recharged, it should be done by professional staff following the specified procedures. After the recharge is finished, the battery must be put back into its packaging.
- When handling batteries, they should be transported in the direction specified by the battery requirements. Inversion and tilting are strictly prohibited.
- Batteries should be protected from impact.
- Do not perform welding, grinding, or similar operations near the battery to prevent sparks or arcs from causing fire hazards.
- Use the battery within the operating temperature range specified in this manual. Refer to [Section 2.3.1 Battery](#) for the battery's operating temperature range.

- Do not use damaged batteries, such as those that have been dropped, collided, or have case dents. Damaged batteries may release flammable gases. Do not store damaged batteries near undamaged products.
- Damaged batteries should not be stored in areas containing flammable materials, and non-professional personnel should keep away.
- During storage, damaged batteries should be monitored to ensure there are no signs of smoke, fire, electrolyte leakage, or overheating.

## **Personal Safety**

- During equipment operation, appropriate personal protective equipment (PPE) shall be worn. In case of malfunctions that may cause personal injury or equipment damage, immediately cease operation, report to the responsible personnel, and take timely and effective protective measures.
- Before using tools, ensure proper use methods are mastered to avoid personal injury or equipment damage.
- During equipment operation, the enclosure temperature is high, posing a risk of burns. Do not touch.
- To ensure personal safety and proper operation, reliable grounding shall be implemented before use.
- When a battery malfunctions, its surface temperature may exceed safe touch limits, presenting a burn risk. Avoid contact.

- Do not open or damage the battery. Released electrolyte may cause harm to skin and eyes. Avoid contact.
- Do not place unrelated items on top of the equipment or insert them into any part of the equipment.
- Do not store flammable items around the equipment.
- Batteries shall not be exposed to fire to prevent explosion and endanger personal safety.
- Do not immerse battery modules in water or other liquids.
- Never short-circuit battery terminals, as this may cause combustion.
- Batteries may pose risks of electric shock and large short-circuit currents. When using batteries, observe the following precautions:
  - Use tools with insulated handles.
  - Wear insulated gloves and shoes.
  - Do not place tools or metal parts on top of the battery.
  - Disconnect the charging power supply before connecting or disconnecting battery terminals.
  - Check if the battery is accidentally grounded. If so, remove the power supply from the ground.
- Do not use water or cleaning agents to clean the internal and external electrical components of the cabinet.
- Do not lean on the equipment or stand/sit on top of it.
- Do not damage any module of the equipment.

## Battery Installation

- Before installing the battery, check whether the packaging is intact. Batteries with damaged packaging must not be used directly.
- During the battery installation process, pay attention to the positive and negative terminals. It is prohibited to short-circuit the positive and negative terminals of the battery.
- During the installation process, use a torque wrench to ensure that the screws are tightened without loosening, and check them regularly.
- After installing the equipment, remove the empty packaging materials in the equipment area, such as cartons, foam, plastics, and cable ties.

## Hazards and Toxicity

### **DANGER**

- Contact between battery terminals and other metals may cause overheating or electrolyte leakage. Since the electrolyte is flammable, immediately remove the battery from fire in case of leakage.
- Vapors generated by burning batteries may irritate the eyes, skin, and throat.

## Battery Abnormalities and Emergency Measures

### **DANGER**

- When electrolyte leakage occurs or there is an unusual odor, avoid contact with the leaked liquid or gas. Non-professionals should not approach. Please contact professional personnel immediately for handling. Professional personnel should wear goggles, rubber gloves, gas masks, protective clothing, etc. to prevent the hazards caused by electrolyte spillage.
- The electrolyte is corrosive and contact may cause skin irritation and chemical burns. If exposed to battery electrolyte, take the following measures:
  - Inhalation: Immediately evacuate personnel from the contaminated area. After moving away, inhale fresh air and seek medical attention.
  - Eye contact: Flush eyes with plenty of water for at least 15 minutes. Do not rub and seek immediate medical help.
  - Skin contact: Wash the affected area with copious amounts of water and soap. Seek medical attention immediately.
  - Ingestion: Seek immediate medical attention.

## Fire Emergency Measures

### **DANGER**

- In case of fire, disconnect the system power supply when it is safe to do so

- Firefighters should avoid contact with high-voltage components during fire suppression. Otherwise, there may be a risk of electric shock.
- Excessive battery temperature may cause battery deformation and damage, as well as electrolyte spillage and toxic gas release. In such cases, wear respiratory protective equipment and do not approach to prevent skin irritation and chemical burns.

## Flood Emergency Measures

### **DANGER**

- Power off the system when it is safe to ensure personal safety.
- If any part of the battery is submerged in water, do not touch it to avoid an electric shock.
- Do not use flood-damaged batteries. Contact a battery recycling company for proper disposal.

## Battery Drop Emergency Measures

### **DANGER**

- When installing the battery, if it drops or sustains severe impact, internal damage to the equipment may occur. In such cases, do not continue to use it to avoid safety risks such as cell leakage or electric shock hazards.

- If a dropped battery exhibits distinctive odor, damage, smoke, or fire, immediately evacuate nearby personnel, alert emergency services, and contact professionals. Trained personnel should use fire-fighting equipment to extinguish flames while ensuring safety.
- If a dropped battery shows no visible deformation or damage, and there is no noticeable odor, smoke, or fire, contact professionals to transport the battery to an open and safe location or coordinate with a recycling company for disposal.

## Battery Recycling and Disposal

- Follow local laws and regulations for proper disposal of used batteries. Do not dispose of batteries as household waste. Improper battery disposal may cause environmental pollution.
- If a battery leaks or becomes damaged, contact technical support or a battery recycling company for proper disposal.
- When a battery reaches the end of its service life, contact a battery recycling company for proper disposal.
- Avoid exposing used batteries to high temperatures or direct sunlight.
- Avoid exposing used batteries to high humidity or corrosive environments.

## 1.6 Handling, Transportation, and Storage Safety

### **WARNING**

- Do not allow direct exposure to rain or snow to prevent water ingress.
- Avoid dropping or subjecting batteries to mechanical impact.
- Do not invert, tilt, or tip over batteries.
- Handle with care to prevent battery damage or short circuits, which could lead to accidents.
- Comply with national and regional laws, regulations, and industry standards for handling, transportation, and storage.

## 1.7 Maintenance and Replacement

### **DANGER**

The equipment operates with high voltage, which can lead to electric shock accidents. These accidents may result in severe personal injury, even loss of life, or significant property damage. Before performing any maintenance tasks, it is essential to first cut off the equipment's power supply and strictly follow the safety guidelines outlined in this manual and other relevant documentation.

- Familiarize yourself with and understand the contents of this manual before performing maintenance on the equipment, and ensure that appropriate tools and testing equipment are available.

- Before conducting maintenance, cut off the equipment's power supply. Follow the instructions on the time-delay discharge label, wait the specified time to ensure the equipment is completely powered off, and then proceed with operations.
- During maintenance, prevent unauthorized personnel from entering the work area. Erect temporary warning signs or install barriers for isolation.
- If the equipment malfunctions, contact our company immediately for after-sales service. Contact information is provided in Chapter 9 Technical Support and After-Sales Service.
- The equipment must be fully repaired before powering up again. Failure to do so may cause the fault to escalate or equipment damage.
- Do not open the equipment without authorization. This poses a risk of electric shock, and resulting malfunctions will not be covered under warranty.
- Operators and maintenance personnel, as well as professional technicians, must receive adequate training on safe equipment operation and maintenance. Operations should be performed under sufficient preventive measures and with personal protective equipment (PPE).
- When moving or rewiring the equipment, first disconnect the power input. After internal energy dissipation is complete and a multimeter confirms no hazardous voltage on the DC bus and internal components to be repaired, maintenance may commence.
- Battery repairs must be performed or supervised by personnel familiar with batteries and required preventive measures.
- Replace the battery with the same type of battery.

- After maintenance operations, immediately inspect to ensure no tools or other components are left inside the equipment.
- When the equipment is not in use for an extended period, the battery should be stored and recharged according to the instructions in this manual.

# 2 Product Introduction

---

## 2.1 Product Information

### Introduction

This product is a battery energy storage system solution composed of key components such as battery cabinets and BCP cabinets. It features high integration and modularity, facilitating transportation, installation, and rapid deployment while greatly shortening the project construction timeline. The energy storage system boasts ultimate safety, stability, and outstanding performance. It can respond to changes in power demand in real time, achieve precise charge-discharge control, and effectively improve energy utilization efficiency.



**Battery Energy Storage System (BESS)**

## Basic Information

Model	Certification
SU836E418KM (Battery Cabinet)	CE
SA914K1ELLW (BCP Cabinet)	CE

## System Parameters

Parameter	Value
System Configuration	3 Battery Cabinets (Max. 8 total supported)
	1 BCP Cabinet
Operating Ambient Temperature Range	-30~55°C
Charge/Discharge Rate	0.5C
Operating Ambient Humidity Range	0~95%RH
Corrosion Protection Grade	C4-M
IP Rating	IP55
Cooling Method	Intelligent liquid cooling solution
Fire Suppression Configuration	Fire Detection and Alarm System
	Ventilation and Air-Exchange System
	Aerosol Fire Suppression System
	Water-Based Fire Suppression System
Allowable Operating Altitude	≤4000m

Noise Level	≤72dB@1m
Wind Load	66m/s
Snow Load	40psf
Seismic Grade	Zone 4
Cell Specifications	3.2V/314Ah
Battery Configuration	416S6P
Rated Energy	2508kWh
Rated Power	1254kW
Rated Voltage	DC 1331.2V
Operating Voltage Range	DC 1123.2~1497.6V

## Battery Cabinet Parameters

Parameter	Value
Dimensions	W: 2000mm
	D: 1700mm
	H: 2400mm
Weight	6.75t
Charge/Discharge Rate	0.5C
Corrosion Protection Grade	C4-M
IP Rating	IP55

Cooling Method	Intelligent Liquid Cooling
Cell Specifications	3.2V/314Ah
Battery Configuration	416S2P
Rated Energy	836kWh
Rated Power	418kW
Rated Voltage	DC 1331.2V
Operating Voltage Range	DC 1123.2~1497.6V

## BCP Cabinet Parameters

Parameter	Value
Dimensions	W: 1700mm
	D: 1295mm
	H: 2400mm
Weight	1440kg
Corrosion Protection Grade	C4-M
IP Rating	IP55
Cooling Method	Intelligent Air Cooling

## 2.2 Product Design

### 2.2.1 Product Appearance

#### Battery Cabinet Appearance

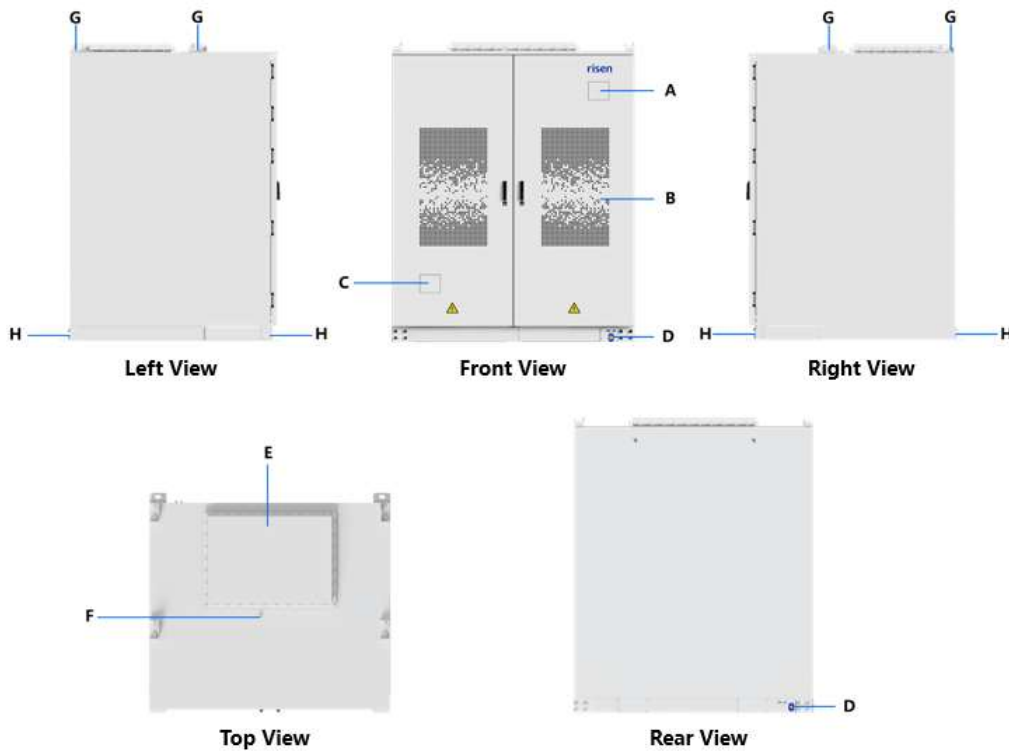

No.	Components	Quantity	Function
A	FSS exhaust fan	1	Vent the combustibile gas inside the cabinet.
C	FSS air inlet	1	
B	Liquid cooling unit	2	For temperature regulation inside the battery cabinet.
D	Grounding terminal	2	For equipment grounding.
E	Explosion relief panel	1	For directional pressure release to prevent

explosion or equipment damage when internal pressure or gas increases sharply.

---

F	FSS water supply port	1	Connect to external water source to supply water for the Water-Based Fire Suppression System in emergencies.
G	Lifting lug	4	For equipment lifting.
H	Fastener	4	For connection and fixing to the foundation.

---

## BCP Cabinet Appearance

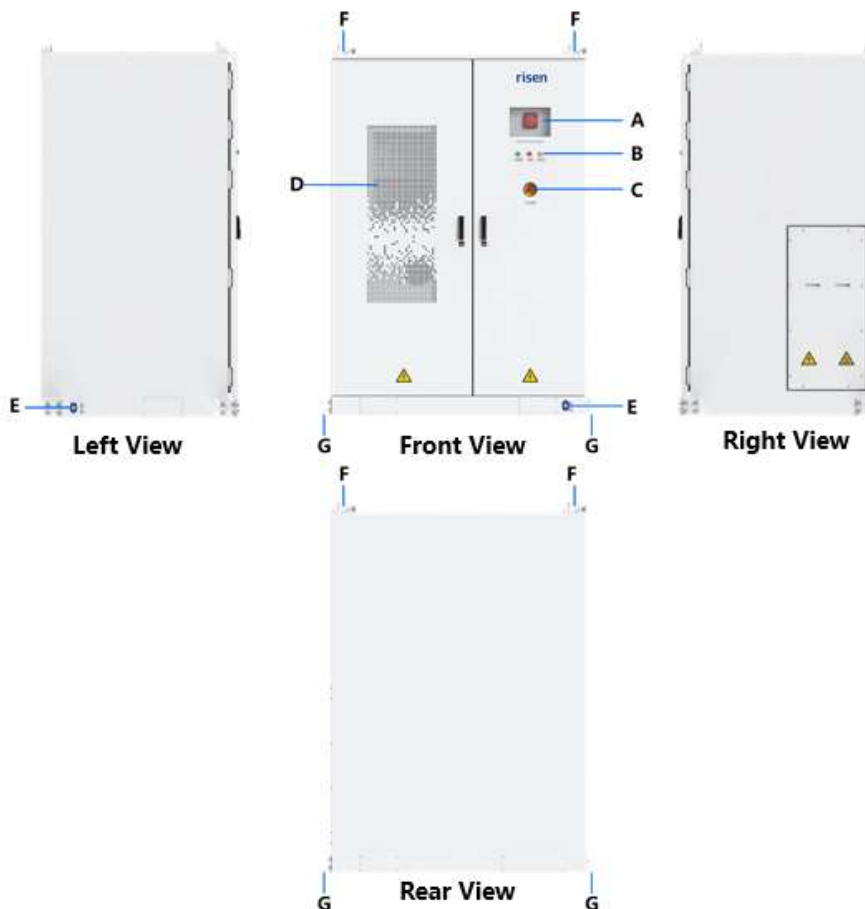

No.	Components	Quantity	Function
A	Audible and visual alarm	1	Emits audible and visual alarms when the fire suppression system is triggered inside the BCP Cabinet.
B	Indicator light	3	Indicates the operation status of the energy storage system.
C	System emergency stop button	1	Used to shut down the energy storage system in emergencies.
D	HVAC	1	Used for dehumidification, ventilation, and temperature regulation inside the BCP Cabinet.
E	Grounding terminal	2	For equipment grounding.
F	Lifting lug	4	For equipment lifting.
G	Fastener	4	For connection and fixing to the foundation.





## 2.2.2 Product Markings

 <b>NOTE</b>
Product markings may vary due to factors such as model, certification standards, production batch, and sales region. The markings listed in this manual do not cover all possible ones. Please refer to the actual markings on the product.

### 2.2.2.1 General Markings

Marking	Meaning
	Brand Marking

### 2.2.2.2 Exterior Markings

Marking	Meaning
	Danger: Electrical Hazard
	Caution: Hot Surface
	Height Limit
	Electric Arc Flash Hazard
	UN3536



Class 9 Dangerous Goods

E-STOP

Emergency Stop



Left Door Opening



Right Door Opening













Grounding Terminal







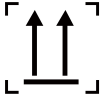

### 2.2.2.3 Nameplate Markings

Marking	Meaning
	Danger: Electrical Hazard
	Warning: Hazard
	Warning: Corrosion Hazard
	Warning: Explosive Hazard
	Caution: Heavy Load

	No Smoking or Open Flames
	Refer to User Manual
	Must Wear Protective Goggles
	Must Wear Protective Gloves
	First Aid
	Emergency Eye Wash Station
	Recycling
	WEEE Recycling
	CE Marking
	TÜV Rheinland Certified

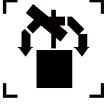
## 2.2.2.4 Outer Packaging Markings

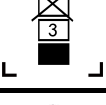
Marking	Meaning
	This Side Up

	Avoid Direct Sunlight
	Do Not Tumble
	Fragile
	Protect from Rain
	Maximum Stacking Layers
	Class 9 Dangerous Goods
	UN Number & China Dangerous Goods Number
50D/Y/xxxx CN/xxxxxxx 2190/730	

## 2.3 Key Components

### 2.3.1 Battery

#### 2.3.1.1 Cell

Parameter	Value	Image
Chemical Composition	Lithium Iron Phosphate (LFP)	 <p>(For reference only)</p>
Form Factor	Prismatic	
Dimensions	W: 174mm	
	H: 207mm	
	T: 72mm	
Weight	5.6±0.3kg	
Rated Capacity	314Ah	
Rated Energy	1004.8Wh	
Rated Voltage	DC 3.2V	
Operating Voltage Range	DC 2.5~3.65V	
Operating Temperature Range	Charge: 0~60°C	
	Discharge: -30~60°C	

## 2.3.1.2 Battery Module

A battery module is composed of multiple cells connected in series and is equipped with one battery module management unit (BMU).

Parameter	Value	Image
Configuration	52S1P	 <p>(For reference only)</p>
Key Components	52 cells	
	1 BMU	
Dimensions	W: 790mm	
	H: 243mm	
	D: 1160mm	
Weight	330kg	
Rated Capacity	314Ah	
Rated Energy	52.24kWh	
Rated Voltage	DC 166.4V	
Operating Voltage Range	DC 145.6~187.2V	

### 2.3.1.3 Battery Cluster

A battery cluster is composed of multiple battery modules connected in series and is equipped with one battery cluster management unit (BCU).

Parameter	Value
Configuration	416S1P
Key Components	8 battery modules
	1 BCU
Rated Capacity	314Ah
Rated Energy	418kWh
Rated Voltage	DC 1331.2V
Operating Voltage Range	DC 1123.2~1497.6V

### 2.3.1.4 Battery Array

A battery array is composed of multiple battery clusters connected in parallel and is managed by the battery array management unit (BAU).

Parameter	Value
Configuration	416S6P
Key Components	6 battery clusters
	6 switchgears, each containing 1 BCU

1 BAU, located in the BCP Cabinet

Rated Capacity	1884Ah
Rated Energy	2508kWh
Rated Power	1254kW
Rated Voltage	DC 1331.2V
Operating Voltage Range	DC 1123.2~1497.6V

### 2.3.2 Battery Management System (BMS)

The battery energy storage system (BESS) employs a multi-tiered battery management system (BMS) for system monitoring and control. Each BMS comprises multiple battery module management units (BMUs), multiple battery cluster management units (BCUs), and one or multiple battery array management units (BAUs).



**Battery Array Management Unit (BAU) (For reference only)**

### 2.3.2.1 Battery Management Units and Functions

The BMU can be used to detect voltage and temperature and perform cell balancing. The BCU can manage BMUs, detect cluster voltage and cluster current, and execute protection functions by switching DC contactors. The BAU can manage BCUs and communicate with Golden Shield (GS).

Function		BMU	BCU	BAU
Measurement	Cell Voltage	✓		
	Cell Temperature	✓		

	Cluster Voltage		✓	
	Cluster Current		✓	
Calculation	SOC		✓	✓
	SOH		✓	✓
	Power Prediction		✓	
Control	Contactor Control		✓	
	Cell Balancing	✓	✓	
Communication	CAN2.0	✓	✓	✓
	RS485		✓	✓
	Ethernet			✓

### 2.3.3 Golden Shield

To provide a universal communication port for battery systems equipped with the supervisory control and data acquisition (SCADA) system or the EMS and to free the EMS from basic system protection, a system controller, namely the Golden Shield (GS) shown in the following figure, is integrated and deployed in the BESS.



**Golden Shield**

### 2.3.3.1 Features and Functions

- Integration of battery system control, including the BMS, cooling devices, BCP, etc.
- Provide a universal communication port for battery systems equipped with SCADA or EMS.
- As a communication adapter, convert various communication protocols (such as RS485, CAN, dry contacts, etc.) of the balance of system (BOS) like BMS, PCS, HVAC, FSS into one communication protocol of the EMS for easy integration.
- Implement basic system protection to prevent equipment, such as batteries and PCS, from being damaged during operation.
- Record data for a short period for troubleshooting.

### 2.3.3.2 Communication Topology

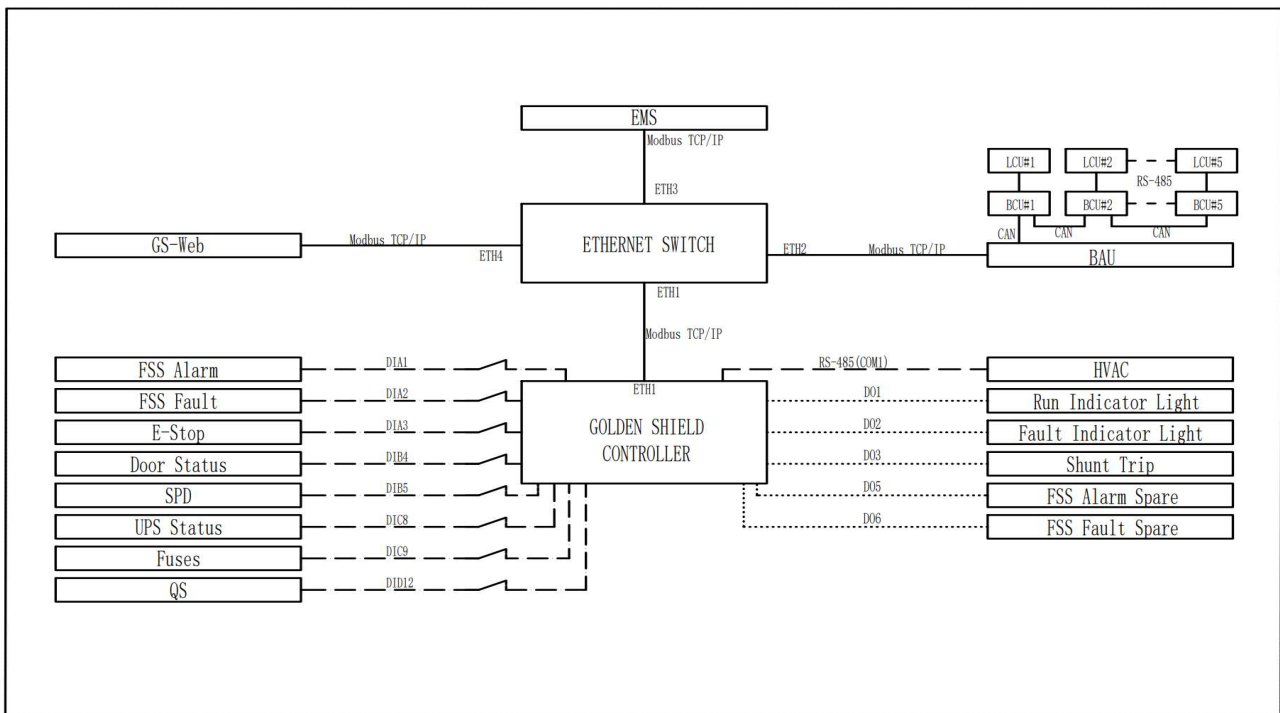

**Golden Shield Communication Topology**

## 2.4 Fire Suppression System

### 2.4.1 Precautions

#### NOTICE

- The battery cabinet is equipped with an automatic fire suppression system. The FSS buttons must not be triggered casually under non-emergency circumstances.
- It is necessary to adhere to the fire suppression codes and regulations of the country and region where the project is situated.
- Fire suppression equipment should be inspected and maintained on a regular basis to ensure all functional parameters are normal.

#### NOTE

If users intend to utilize the Water-Based Fire Suppression System integrated into the ESS (where applicable), they shall comply with the laws, regulations, standards, and codes of the project's location, and independently design and construct supporting fire wastewater treatment solutions and facilities based on the actual project conditions. It is necessary to ensure that such solutions and facilities fully meet the requirements regarding legality, safety, and long-term effectiveness. SYL assumes no liability for any matters related to fire wastewater treatment.

## 2.4.2 Fire Suppression System Overview

The fire suppression system is based on core subsystems such as the Fire Detection and Alarm System, Ventilation and Air-Exchange System, Aerosol Fire Suppression System, and Water-Based Fire Suppression System. Through seamless integration with the fire alarm control panel and the Golden Shield controller, it establishes a protection system covering the entire process of fire early warning, risk prevention, and fire response. Relying on a multi-layered protection mechanism, it provides all-dimensional fire safety for energy storage systems. It can implement efficient fire suppression in stages for different phases of fire germination, development, and spread, minimizing losses to the energy storage system.

## 2.4.3 Fire Suppression System Components

- **Fire Detection and Alarm System**

Smoke detectors and heat detectors are deployed at key positions inside the battery cabinet to monitor smoke concentration and temperature in real time. When the detected value exceeds the preset safety threshold, an early warning signal is immediately sent to the fire alarm control panel to achieve early and accurate identification of fire hazards and intervention.

- **Ventilation and Air-Exchange System**

Combustible gas detectors monitor the concentration of combustible gases inside the battery cabinet in real time. When the concentration reaches the set safety threshold, it immediately sends an early warning signal to the fire alarm control panel and

automatically activates the mechanical ventilation devices. Through forced convection, accumulated combustible gases are discharged to control the concentration within a safe range, reducing the risk of deflagration at the source.

- **Aerosol Fire Suppression System**

It can quickly achieve total flooding protection inside the battery cabinet. Through a dual fire-extinguishing mechanism of chemical inhibition of combustion chain reactions and physical oxygen isolation, it rapidly suppresses the spread of initial fires, effectively addressing electrical fires and battery thermal runaway.

- **Water-Based Fire Suppression System**

As the ultimate fire-extinguishing measure, it can quickly connect to an external water source through the FSS water supply port, activate the water sprinkler devices to precisely cool and reduce the temperature in the open fire area, rapidly extinguish the open fire, and continue sprinkling to prevent lithium battery re-ignition. Meanwhile, a physical isolation barrier is constructed through dense sprinkling to block the spread of fire, creating safe conditions for subsequent emergency response.

## 2.4.4 Fire Suppression System Logic Diagram

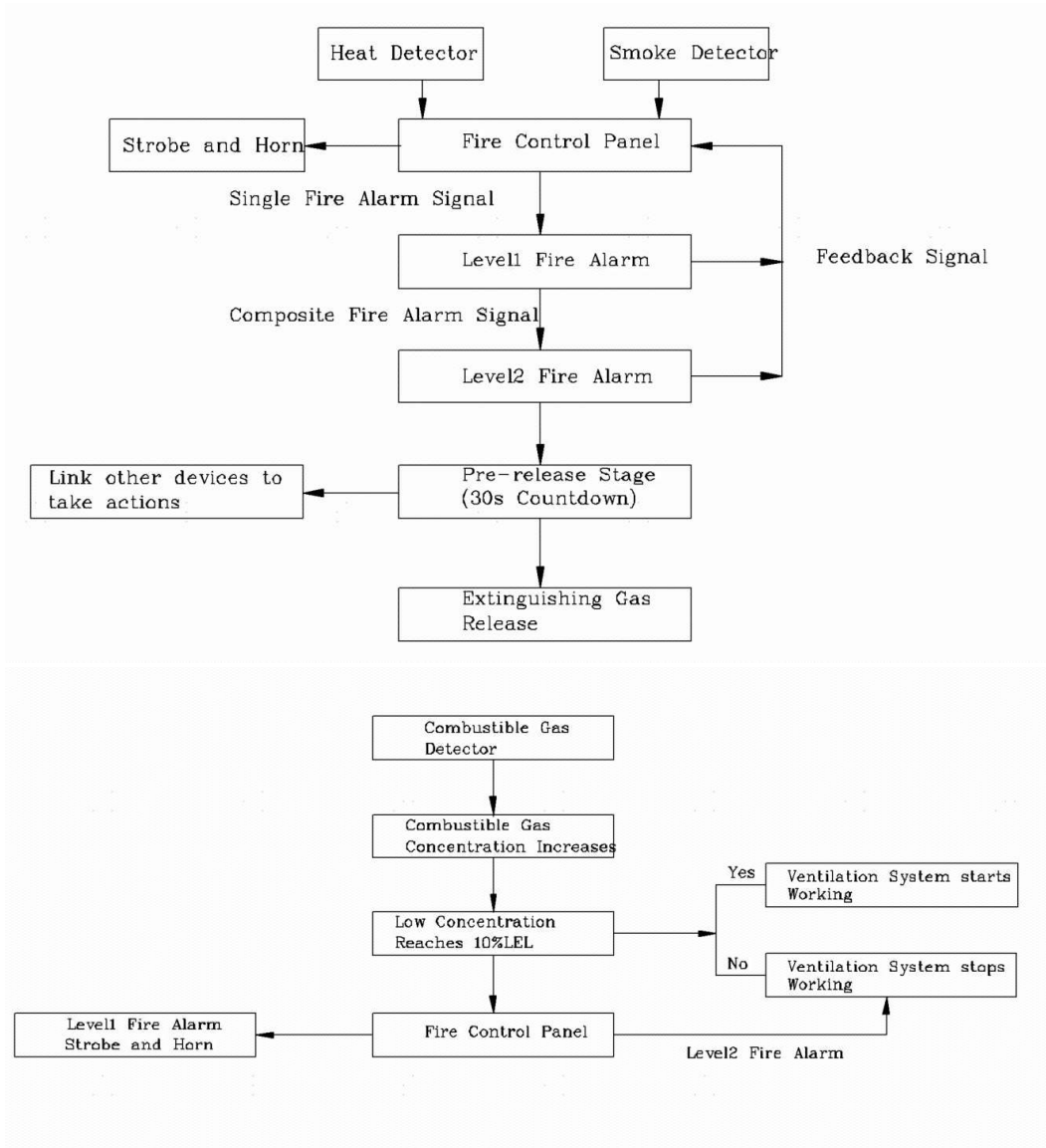

**Fire Suppression System Logic Diagram**

## 2.4.5 Water Supply for Water-Based Fire Suppression System

**⚠ NOTICE**

The piping of the Water-Based Fire Suppression System shall remain dry under

normal conditions. External water source connection via the FSS water supply port is strictly permitted only during emergency situations (e.g., fire incidents).

An FSS water supply interface is reserved on the top of the battery cabinet. On-site personnel may decide whether to connect the water supply pipeline in advance based on actual needs.

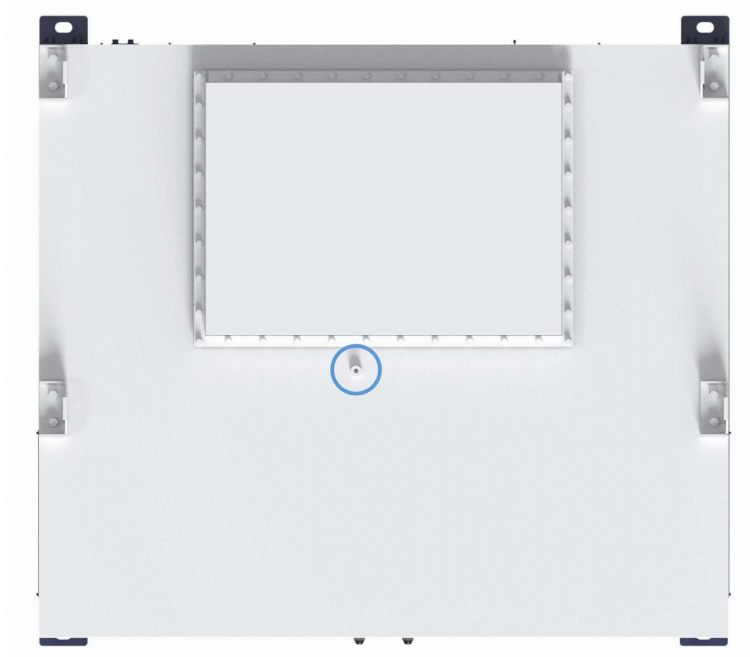

**FSS Water Supply Port**

## 2.4.6 Post-Discharge Handling Measures for Aerosol Fire Suppression System

### 2.4.6.1 Precautions

#### **DANGER**

- Flammable gases may be present inside the battery cabinet. It is strictly prohibited to carry open flames, heat sources, or lit cigarettes into the hazardous area to prevent re-ignition or explosion.

- Toxic gases may be present. Before entering, personal protective measures must be taken, and respiratory protective equipment complying with local regulations must be worn to ensure life safety and health.
- After firefighting, professional firefighters must assess the internal safety risks. The cabinet door can only be opened after confirming that no hazards exist.

## NOTICE

During the handling process, portable fire extinguishers must be equipped throughout to prevent re-ignition.

### 2.4.6.2 Handling Measures

#### Ventilation and Inspection

- After the aerosol fire suppression device is discharged, keep the protected area airtight for 10 minutes or more. Ventilation or opening doors, windows, fire doors, or other openings is prohibited during this period.
- Thoroughly ventilate the area using ventilation systems, fans, or by opening windows before entering. Wear respiratory protective equipment throughout the process to avoid inhaling toxic substances and aerosol fire extinguishing agents.
- Conduct a comprehensive inspection after entering to confirm the fire is extinguished and there are no localized heat sources or re-ignition points.

## Residue Handling

- In high-humidity environments, dehumidification must be performed after ventilation to prevent residues from absorbing moisture, which could corrode metals and electronic devices or cause circuit board short-circuits.
- For aerosol fire extinguishing agent residues remaining after ventilation, promptly inspect and completely remove them:
  1. For aerosol residues on equipment and circuit board surfaces, use a lint-free cloth to gently press and absorb the liquid.

**i Note:** Directly wiping circuit boards is prohibited to avoid scratches or component damage. Paper products are forbidden to prevent fiber residue.
  2. Gently brush off particulate matter and dried liquid residues with a toothbrush.
  3. Use compressed air to quickly blow in a single direction for a short time to remove remaining dust and fine residues.

## Dismantling and Disposal

- The casing of the aerosol fire suppression device may remain hot for a period of time after activation. Wear protective gloves and follow standard procedures when dismantling—do not touch directly.
- Dispose of the dismantled aerosol fire suppression device in accordance with local regulations.
- Contact us as soon as possible to replace the aerosol fire suppression device and re-

commission it. For contact information, please refer to Chapter [9 Technical Support and After-Sales Service](#).

## 2.5 Thermal Management System

### 2.5.1 Precautions

 <b>CAUTION</b>	
<ul style="list-style-type: none"> <li>● No blocking of air inlets and outlets for the thermal management system.</li> <li>● Caution: risk of burns. The surfaces of the thermal management system reach high temperatures during operation and remain hot for a period after shutdown.</li> </ul>	

### 2.5.2 Battery Cabinet Liquid Cooling Unit

Each battery cabinet is equipped with two liquid cooling units.

Parameter	Value
Cooling Capacity	5kW
Heating Capacity	2.5kW
Supply Voltage	AC 220V±15%
	50/60±3Hz
Maximum Operating Current	15.8A
Operating Ambient	-30~55°C

Temperature Range	
Refrigerant Type	R513A
Coolant Type	50% Ethylene Glycol Aqueous Solution
IP Rating	IPX5
Corrosion Protection Grade	C4M
Permissible Operating Altitude	0~4000m <b>Note:</b> When exceeding 1000m, derated operation is allowed.
Noise Level	≤70dB(A)



## 2.5.3 BCP Cabinet HVAC



### 2.5.3.1 Parameters

Parameter	Value
Cooling Capacity	3kW
Heating Capacity	2.5kW
Supply Voltage	AC 220V±15% 50/60Hz
Maximum Operating Current	12A
Operating Ambient	Heating: -40~25°C
Temperature Range	Cooling: -15~55°C

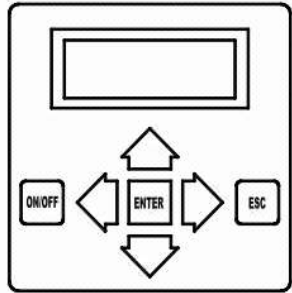
Operating Ambient Humidity	5%~95%RH (non-condensing)
Range	
Refrigerant Type	R134a
IP Rating	IPX5
Corrosion Protection Grade	C4
Permissible Operating Altitude	0~4000m
	<b>Note:</b> When exceeding 1000m, derated operation is allowed.
Noise Level	≤65dB(A)

### 2.5.3.2 Controller

Button	Name	Description	Image
ON/OFF	Power On/Off Button	Turn the unit on or off.	 <p>(For reference only)</p>
	Up Arrow Button	Select the previous record or menu, or increase the setting value (only applicable to the password).	
	Down Arrow Button	Select the next record or	

	Button	menu, or decrease the setting value (only applicable to the password).
		Increase the setting value, or
	Left Arrow Button	select the previous digit of data when operating the password.
		Increase the setting value, or
	Right Arrow Button	select the next digit of data when operating the password.
ENTER	Enter Button	Confirm the input.
ESC	Escape Button	Return to the previous menu.

- After the unit is powered on, on any interface, if there is no button operation for 60 consecutive seconds, it will automatically return to the normal display interface.
- After the system is powered up, press any button and the backlight will turn on. If there is no button operation for 60 consecutive seconds, the backlight will turn off.
- The operation password of the unit is "0001". On the normal display interface, press the ENTER button to enter the password input interface. Use the left arrow and right arrow buttons to

select the input position, and the up arrow and down arrow buttons to make modifications.

After entering the password, press the ENTER button to confirm. If the password is incorrect,

an error message will be displayed on the interface, and you cannot modify the unit settings.

If the password is correct, you will enter the main menu and can edit the unit settings.

**i Note:** The actual parameters in the menu will be set at the factory according to actual requirements.

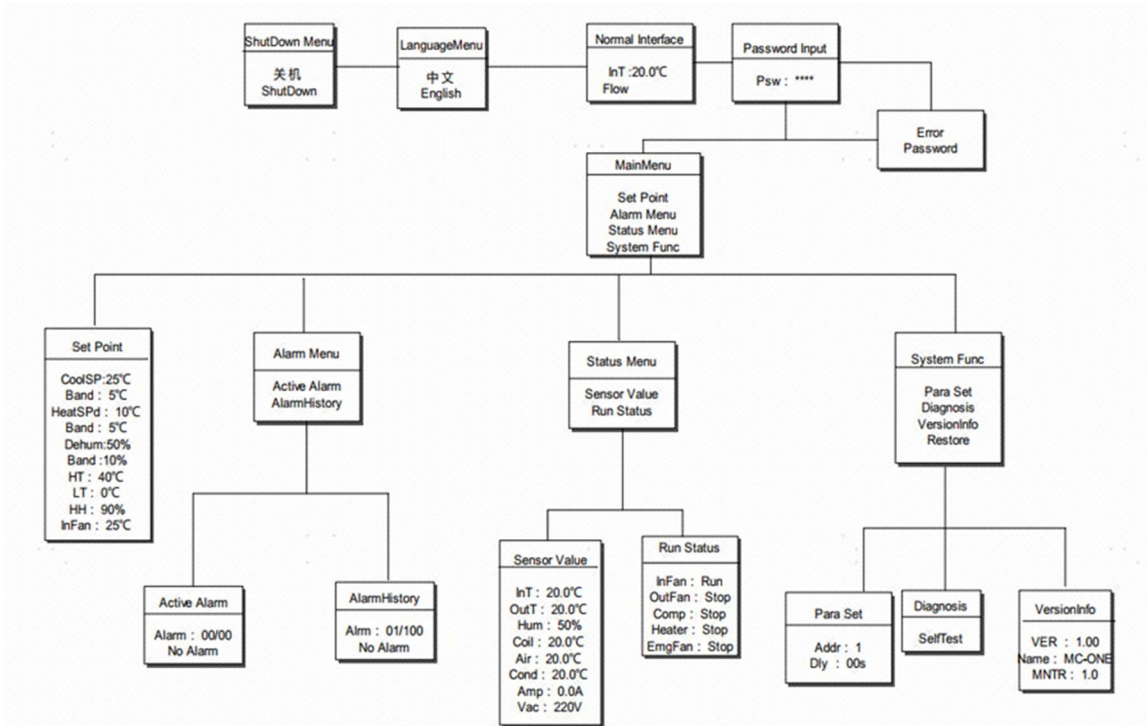

**Menu Structure Diagram (For reference only)**

# 3 Transportation and Storage

---

## 3.1 Handling and Transportation

### 3.1.1 Precautions

#### **WARNING**

- Do not expose to direct rain or snow to prevent water ingress.
- Avoid dropping or mechanical impact.
- Do not tilt or invert.

**i Note:** In case of any of the above anomalies, refer immediately to the emergency measures in Section [1.5 Battery Safety](#) for resolution.

#### **NOTICE**

This product is certified under UN38.3 (Section 38.3 of the Sixth Revised Edition of the *Recommendations on the Transport of Dangerous Goods: Manual of Tests and Criteria*) and *SN/T 0370.2-2009 Rules for the Inspection of Export Dangerous*

*Goods Packaging-Part 2: Performance Testing*, and is classified as Class 9 dangerous goods.

## NOTE

Energy storage systems are subject to various external conditions such as temperature, transportation, and storage. Their specifications shall be based on the date of manufacture.

### 3.1.2 Handling

## WARNING

- Energy storage systems must comply with the laws, regulations, and industry standards of the country and region where they are located during handling operations.
- During handling operations, handle with care. Rough handling may cause battery short circuits or damage inside the enclosure, and may also result in battery leakage, rupture, fire, or explosion.

## 3.1.3 Transportation

### Transportation Preparation

- Before commencing transportation, batteries must be inspected. Batteries shall be intact without visible damage, abnormal odors, smoke, fire, etc. If any of these conditions occur, transportation is prohibited, and emergency measures must be initiated immediately. For specific emergency measures, refer to Section [1.5 Battery Safety](#).
- Before commencing transportation, the outer packaging of the product must be inspected to ensure it is secure.
- Before commencing transportation, ensure the product and its outer packaging comply with the requirements of transportation vehicles (e.g., trucks, vessels).

### Transportation Requirements

- During transportation, the product must be fully protected against moisture.
- For sea transportation, comply with the *International Maritime Dangerous Goods Code* (IMDG CODE).
- For road transportation, comply with the *European Agreement concerning the International Carriage of Dangerous Goods by Road* (ADR) or *Regulations Concerning Road Transportation of Dangerous Goods* (JT/T 617).
- Meet the regulatory requirements of the country of departure, transit countries, and country of destination.
- Comply with other applicable international dangerous goods transportation regulations.

## 3.2 Storage

### 3.2.1 Precautions

#### NOTICE

- Storage environments must meet local regulations and standard requirements.
- For extended storage, qualified personnel must perform inspections and tests before returning the battery to service.
- When storing batteries, place them according to the packaging markings and ensure proper orientation. Do not invert or tilt.
- When stacking battery packages, comply with the stacking limits specified on the outer packaging.
- Handle batteries with care during handling to avoid damage.

#### NOTE

- During storage, relevant data records (e.g., temperature, humidity, storage environment) must be maintained in accordance with the product storage requirements in this manual.
- During storage, battery maintenance must be performed according to the maintenance requirements in this manual. For details, refer to Section [7.2 Battery System Maintenance](#).

- Long-term storage of batteries is not recommended. Long-term storage of lithium-ion batteries causes irreversible capacity loss. After 12 months of storage at the recommended temperature, the typical irreversible capacity loss is 3% to 6%.

### 3.2.2 Storage Requirements

- Recommended storage ambient temperature:  $\leq 35^{\circ}\text{C}$ .
- Recommended storage ambient humidity:  $< 60\% \text{ RH}$ .
- Recommended battery system/spare battery modules storage SOC: 30%~50%. During storage, all external power-consuming devices must be disconnected. Perform regular inspections, maintain detailed inspection records, and promptly address any abnormal conditions.
- Store in a dry, clean, and well-ventilated warehouse to prevent dust and moisture ingress and ensure no short circuits.
- Avoid contact with corrosive organic solvents or gases to prevent battery corrosion and rust.
- Avoid direct sunlight.
- During storage, if any questions arise, please contact the after-sales service for consultation and handling. For contact information, refer to Chapter [9 Technical Support and After-Sales Service](#).

# 4 Product Installation

---

## 4.1 Precautions

### WARNING

- Battery energy storage systems are high-voltage devices classified as dangerous goods. Improper operation by unqualified personnel may result in severe consequences such as electric shock, combustion, or explosion.
- Battery energy storage systems must be installed and maintained by qualified technical personnel and used strictly in accordance with relevant safety regulations.

## 4.2 Pre-Installation Inspection

### 4.2.1 Outer Packaging Inspection

Before opening the outer packaging of the product, inspect it for visible damage (e.g., tears, cracks, or other signs of potential internal damage) and verify the product model. If packaging irregularities or model discrepancies are found, contact us immediately. Contact





information is provided in Chapter 9 Technical Support and After-Sales Service.





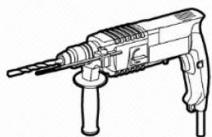
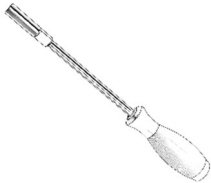

## 4.2.2 Delivered Items Inspection

After opening the outer packaging of the product, inspect the cabinet itself and internal equipment for integrity and visible damage. Refer to the *Packing List* to check whether the spare parts and accessories provided are complete and intact. If any damage to the cabinet/equipment or missing spare parts are found, contact us immediately.



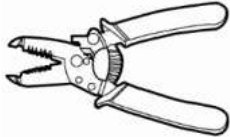
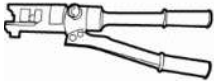
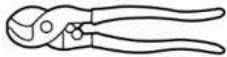
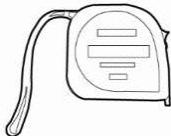

## 4.3 Pre-Installation Preparation

### 4.3.1 Tools and Instruments

Name	Purpose	Image
Electric Drill and $\Phi 16$ Drill Bit	For making holes in expansion bolts.	
Screwdriver and Socket Set	For the installation of grounding wires, power cables, rubber conduits, and forklift hole covers.	
Torque Wrench	For confirming the torque of fasteners.	
Marker Pen	For torque markings.	
Zip Ties	For cable fixation.	

Level meter	For leveling.	
Multimeter	For continuity testing.	
Wire Stripper	For removing insulation from the ends of cables.	
Hydraulic Pliers	For crimping terminals and cables.	
Cable Cutter	For cutting cables.	
Tape Measure	For measuring dimensions.	
Heat Gun	For shrinking heat shrink tubing.	
Heat Shrink Tubing	For protecting wire and terminal connections.	
Cold Crimp Terminal Pliers	For crimping terminals and cables.	

## 4.3.2 Personal Protective Equipment

Name	Purpose	Image
Insulating Gloves	For electrical insulation protection.	
Insulating Shoes	For electrical insulation protection.	
Safety Goggles	For arc flash protection.	
Dust Mask	For dust protection.	

**Note:** Personal protective equipment of Category 1 or higher shall be worn.

## 4.4 Installation Requirements

### 4.4.1 Installation Environment Requirements

- Installation environments must comply with relevant international, national, and regional laws, regulations, and standards.
- For areas prone to natural disasters (e.g., floods, debris flows, earthquakes, typhoons), appropriate preventive measures must be implemented during installation.
- Install in a dry, well-ventilated environment and securely fasten equipment to a solid, flat

support surface.

- Ensure the installation location is clean, free of excessive infrared radiation, organic solvents, and corrosive gases.
- Keep the installation location away from ignition sources and heat sources. Do not store flammable or explosive materials near the equipment.
- Avoid water accumulation at the installation location. Keep it away from water sources to prevent water ingress.
- During operation, the heat dissipation area generates high temperatures. Avoid installing the equipment in easily accessible locations.
- Do not block vents or cooling systems during operation to prevent overheating and fire hazards.
- Never place the equipment in environments with flammable/explosive gases or fumes, and avoid any operations in such environments.

**i Note:**

- The operation and service life of the energy storage system are related to the operating temperature. Install the equipment in an environment with a temperature equal to or better than the ambient temperature conditions.
- When the cell temperature is low, the system automatically derates charging power. If the cell temperature is below 0°C before system startup, the minimum cell temperature must be heated to above 0°C before charging begins.

## 4.4.2 Installation Foundation Requirements

### NOTE

The picture in this section is for illustrative purposes only. The on-site construction and fabrication of the installation foundation must be carried out in strict accordance with the final foundation drawing.

- The bottoms of the battery cabinets and the BCP cabinet must be supported by a concrete foundation with sufficient strength, which can provide adequate support for the cabinet bodies. Additionally, the height of the concrete base must be  $\geq 300\text{mm}$ .
- Use a level meter to measure the foundation levelness, ensuring it is  $\leq 5\text{mm}$ . If the levelness exceeds 5mm, level it out with stainless steel shims. A levelness  $\geq 5\text{mm}$  may cause long-term issues such as equipment frame deformation, insufficient door sealing leading to water ingress, door malfunctions, or liquid-cooling pipe leakage.

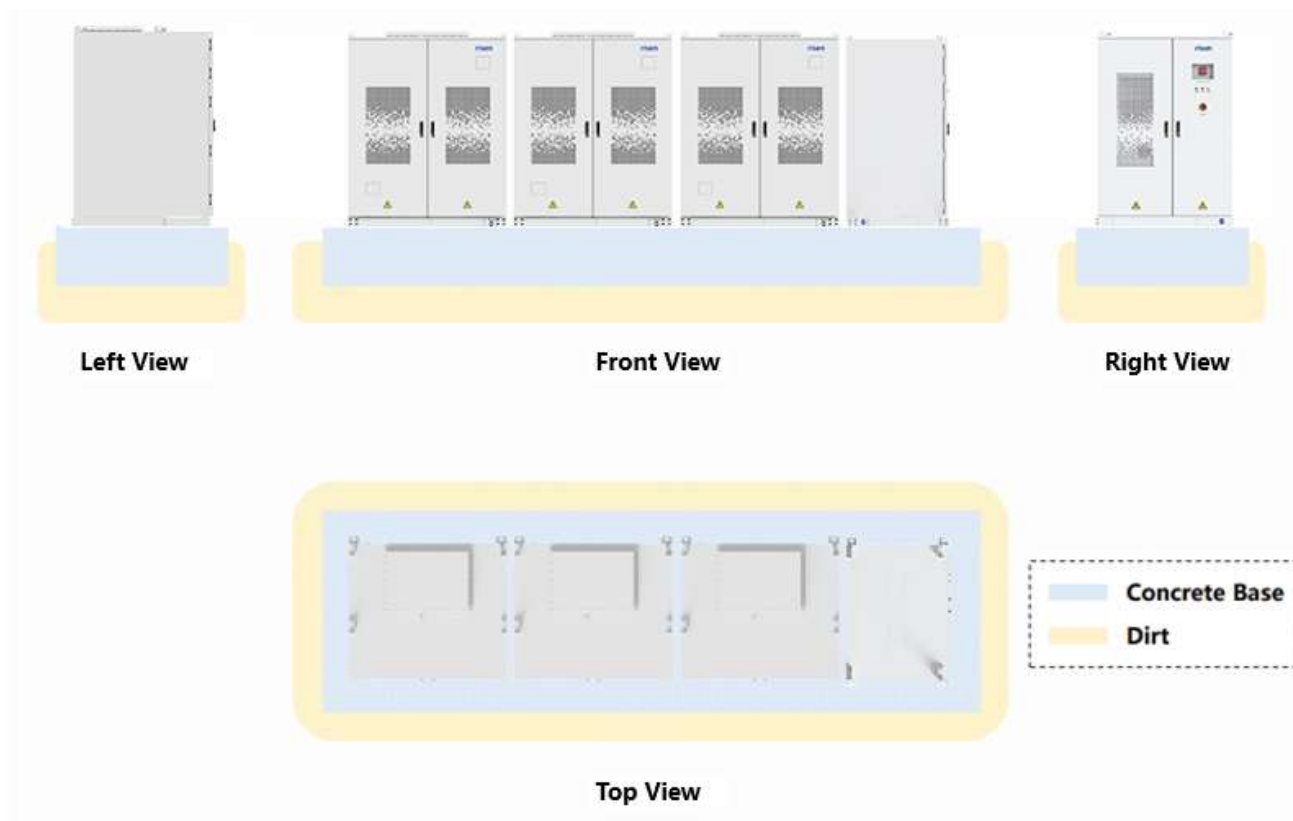

**Installation Foundation (For reference only)**

### 4.4.3 Installation Space Requirements

#### **⚠ WARNING**

When installing the equipment, ensure that there are no flammable or explosive materials in the vicinity and leave sufficient space for heat dissipation and safe separation.

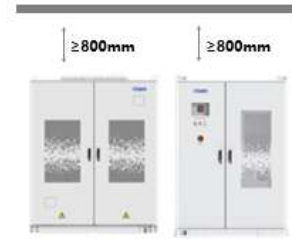
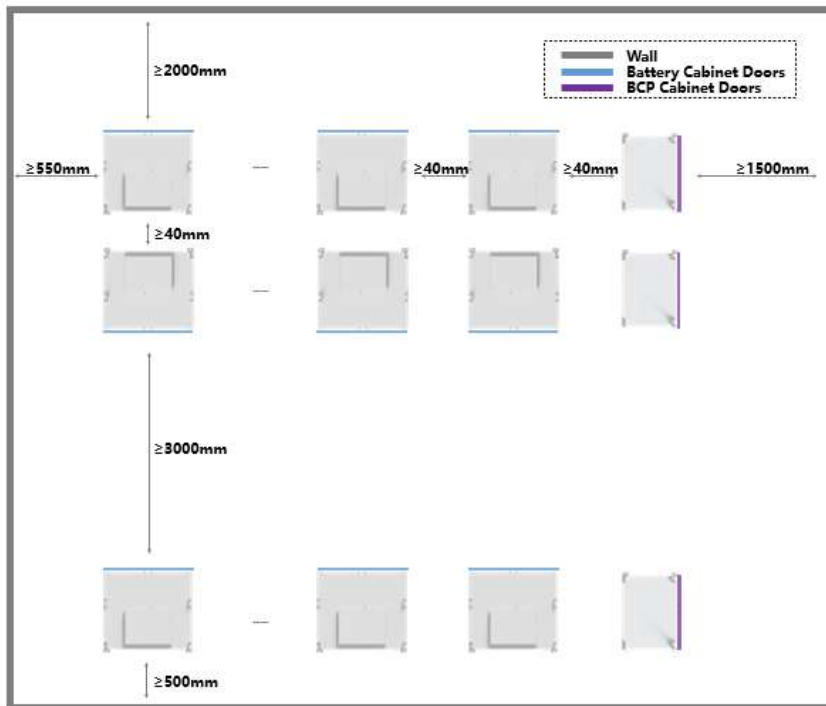

**Installation Space Requirements**

## 4.5 Equipment Installation

### 4.5.1 Equipment Handling

Forklifts or hoisting equipment can be selected to carry out equipment handling and lifting operations according to the actual conditions of the project site.

#### 4.5.1.1 Forklifts

Each Battery cabinet/BCP cabinet is equipped with forklift holes on its front side, facilitating equipment handling and lifting operations via forklifts.

#### 4.5.1.2 Hoisting

## **WARNING**

- During crane operations, no personnel are allowed within a 5m to 10m radius of the operation area.
- Never stand under the crane boom or beneath lifted/moving machinery to prevent injury or fatality.
- Lifting angles must be  $\geq 60^\circ$ . Ensure no personnel or obstacles are present in the vicinity before lifting.
- Suspend lifting operations during adverse weather conditions such as wind force  $\geq$  Beaufort scale 6, heavy rain, snow, or fog.
- Immediately halt operations if abnormal conditions occur, including unusual noises, deformation, or weld cracks in the equipment.

## **CAUTION**

- Select an appropriate crane based on site conditions and the weight of the product.
- Equip 4 steel wire ropes and 4 shackles according to the dimensions and weight of the product, ensuring they have suitable lengths and load-bearing capacities for safe and reliable operation.
- Lifting or lowering processes must be conducted at a constant speed, ensuring acceleration  $\leq 0.1g$  (i.e.,  $\leq 0.98 \text{ m/s}^2$ ).

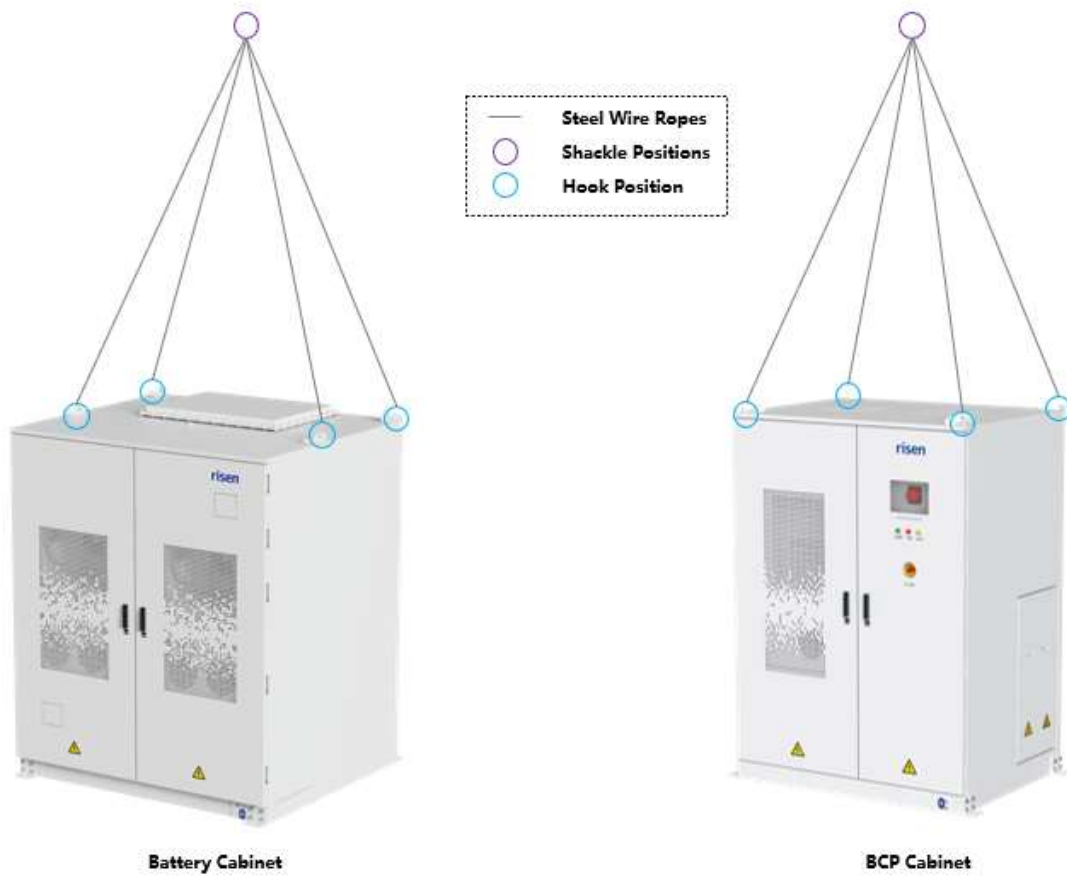

**Hoisting Schematic Diagram**

## 4.5.2 Equipment Fixing

### **⚠ NOTICE**

Before fixing the equipment, ensure the foundation levelness meets requirements (i.e., foundation levelness  $\leq 5\text{mm}$ ). If the foundation levelness exceeds 5mm, use stainless steel shims for leveling.

### 4.5.2.1 Equipment Leveling

1. After the equipment is placed, use a level to measure the levelness. The levelness must

be  $\leq 5\text{mm}$ . If it exceeds 5mm, use stainless steel shims for leveling.

2. After leveling, perform open/close operations on all cabinet doors to ensure smooth movement. If doors do not operate smoothly, re-adjust the leveling until all doors function properly.

## 4.5.2.2 Installation of Fasteners

1. Determine the positions of expansion bolt fixing holes and drill holes to embed M16 $\times$ 100 expansion bolts.
2. Install the fasteners on the foundation.
3. Use M16 $\times$ 40 assembly bolts to secure the fasteners to the cabinet. Tightening torque: 127.50~150.00N·m.

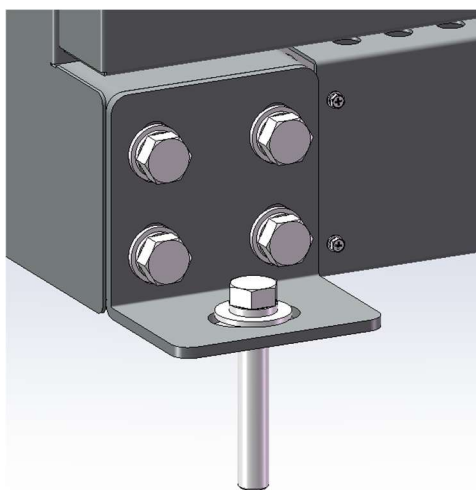

**Fastener Installation**

### 4.5.2.3 Installation of Forklift Hole Cover Plates

Each Battery cabinet/BCP cabinet is equipped with a total of 4 forklift holes on its front and rear sides. After the handling is completed, it is necessary to use M4×10 combination bolts to install the cover plates to the forklift holes. Tightening torque: 2.38~2.80 N·m.

### 4.5.3 Equipment Grounding

Each Battery cabinet and BCP cabinet is equipped with two grounding terminals, and either of the two terminals can be selected for grounding operation based on site requirements.

#### Installation of Grounding Cables

1. Grounding Cable Fabrication: It is recommended to use a copper cable lug compatible with M10 bolt holes, crimped with a copper wire of  $\geq 50 \text{ mm}^2$  cross-sectional area or aluminum wire of equivalent ampacity to form the grounding cable.
2. Secure the grounding cable with M10×25 assembly bolts. Tightening torque: 37.49~44.10N·m.

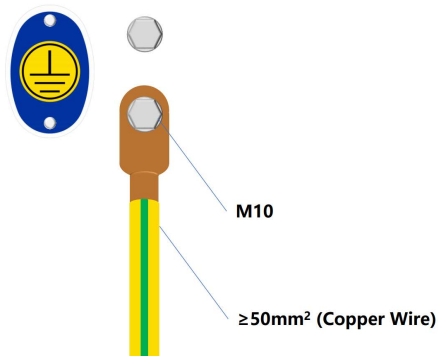

**Grounding Cable Connection**

## 4.5.4 Wiring and Sealing

### Battery Cabinet Cable Inlet/Outlet Areas

Two cable inlet/outlet areas are reserved at the bottom of the battery cabinet, and holes have been pre-drilled within these areas. These areas can be used for the routing of the battery cabinet's DC power cables, auxiliary power cables, and communication cables. After cable routing, it is recommended to seal the holes within these areas with fireproof putty to ensure the sealing performance inside the battery cabinet.

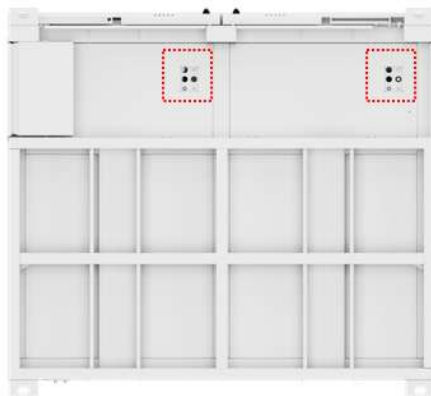

Bottom View

----- Wire - passing holes of the battery cabinet  
(DC power supply wire / auxiliary power supply wire /  
communication wire)

### BCP Cabinet Cable Inlet/Outlet Areas

Three cable inlet/outlet areas are reserved at the bottom of the BCP cabinet, which can be used for the routing of the battery cabinet's DC power cables/auxiliary power cables/communication cables, PCS power cables, and BCP cabinet's auxiliary power cables/communication cables. During shipment, all cable inlet/outlet areas are sealed with aluminum cover plates. On-site, the cover plates can be drilled and adjusted according to actual needs. After cable routing, it is recommended to seal the areas with fireproof putty to

ensure the sealing performance inside the BCP Cabinet.

**i Note:** For the routing of BCP cabinet' s auxiliary power cables/communication cables, it is recommended to use the cable inlet/outlet area shown in the figure below, the other two can also be selected.

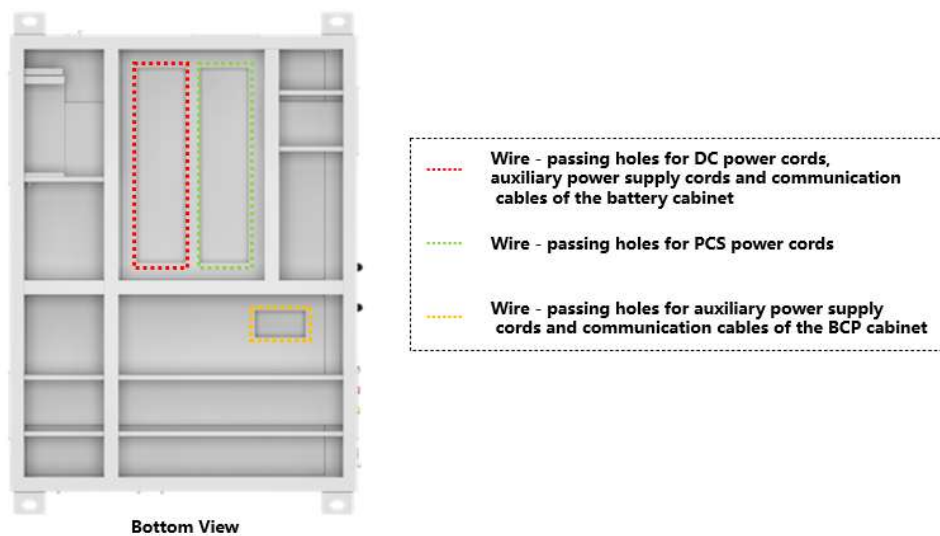

## 4.6 Post-Installation Inspection

- Use a level to check the levelness, ensuring that the levelness is  $\leq 5\text{mm}$ .
- Perform open and close operations on all cabinet doors to ensure smooth movement without abnormal noise.
- Inspect the tightness of each fastener to confirm the secure connection between the cabinet and the foundation.
- Check the grounding cable for a secure connection and verify effective grounding using a multimeter.
- Ensure the bottom cover plate is tightly sealed with fireproofing putty after wiring.

# 5 Electrical Connection

---

## 5.1 Precautions

### DANGER

- Before performing electrical connections, fully read Chapter [1 Safety Precautions](#) of this manual and follow all requirements therein.
- Never touch live parts.

### WARNING

- Electrical connection operations must be performed by qualified electrical personnel.
- Operators must wear personal protective equipment (PPE) during electrical connections.

**⚠ CAUTION**

Tools used for battery power connection installation shall be insulated or shall minimize exposed metal areas. At least the handle portion must be insulated.

**⚠ NOTICE**



Equipment damage resulting from incorrect wiring shall not be covered under the equipment warranty.





## 5.2 Pre-Connection Inspection

- Ensure that both AC and DC sides are not energized.
- Before connecting the cables, if the auxiliary power supply is supplied by a station-level transformer, it is necessary to confirm that the voltage between the neutral wire and the ground wire on the line side of the auxiliary power supply inlet is lower than 2V.



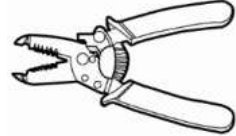
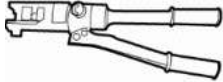
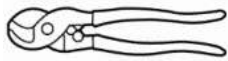
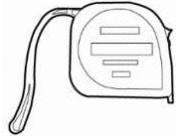

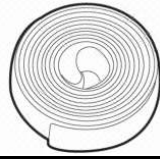
## 5.3 Pre-Connection Preparation

### 5.3.1 Tools and Instruments

Name	Purpose	Image
Screwdriver and Socket Set	For cable installation.	
Zip Ties	For cable fixation.	

Multimeter	For continuity testing.	
Wire Stripper	For removing insulation from the ends of cables.	
Hydraulic Pliers	For crimping terminals and cables.	
Cable Cutter	For cutting cables.	
Tape Measure	For measuring dimensions.	
Heat Gun	For shrinking heat shrink tubing.	
Heat Shrink Tubing	For protecting wire and terminal connections.	
Cold Crimp Terminal Pliers	For crimping terminals and cables.	

## 5.3.2 Personal Protective Equipment

Name	Purpose	Image
Protective Clothing	For electrical insulation protection.	
Insulating Gloves	For electrical insulation protection.	
Insulating Shoes	For electrical insulation protection.	
Safety Goggles	For arc flash protection.	

**Note:** Personal protective equipment of Category 1 or higher shall be worn.

## 5.4 Battery Cabinet Electrical Connections

### 5.4.1 Panel and Functions

#### 5.4.1.1 Battery Module Panel

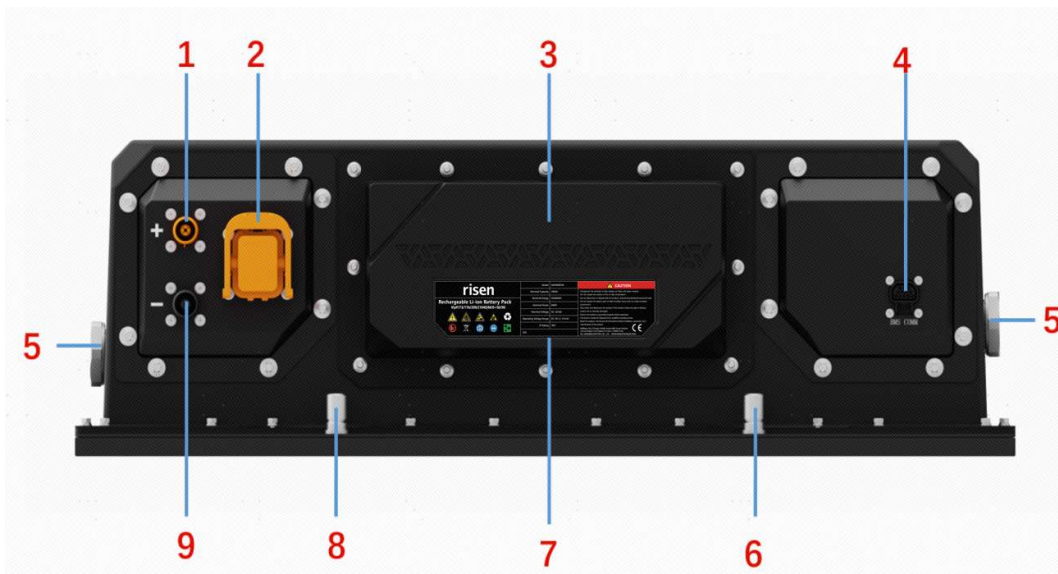

**Battery Module (For reference only)**

No.	Name	Description
1	+	Positive terminal of the battery module.
2	MSD	Manual service disconnect switch. Remove it before transportation and install it before operation.
3	BMU	BMU mounting panel
4	BMS COMM	Supplies power for BMU communication, including a 24V power source and CAN communication.

5	Explosion-proof valve	Balances the pressure difference between the inside and outside of the battery module.
6	Coolant outlet	Battery module liquid cooling coolant outlet.
7	Nameplate	Display battery module parameters.
8	Coolant inlet	Battery module liquid cooling coolant inlet.
9	-	Negative terminal of the battery module.

### 5.4.1.2 Switchgear Panel

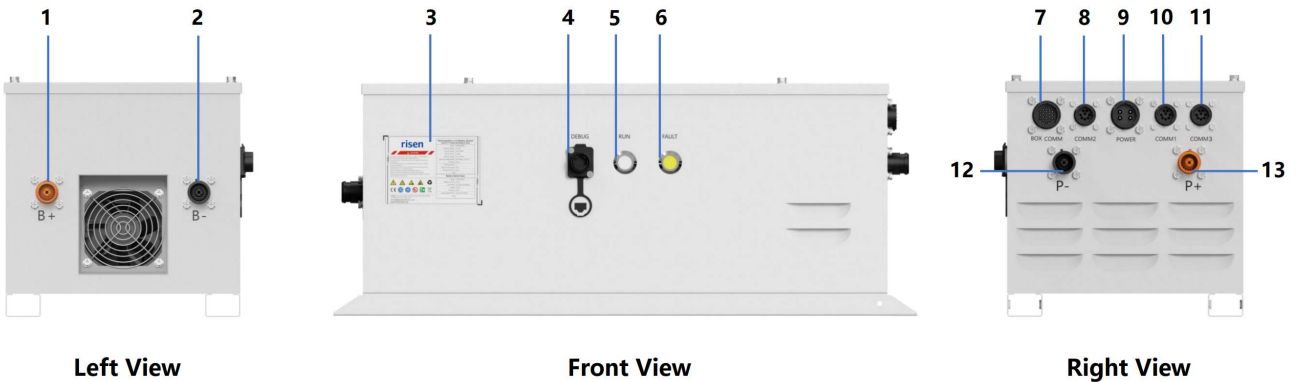

**Switchgear Panel**

No.	Name	Description
1	B+	Connect to the positive terminal of the farthest battery module above the switchgear.
2	B-	Connect to the negative terminal of the nearest battery module above the switchgear.
3	Nameplate	Display switchgear parameters.

4	DEBUG	BCU debug interface.
5	RUN	Battery cluster operation indicator.
6	FAULT	Battery cluster fault indicator.
7	BOX COMM	Power supply for multi-device communication inside the cabinet.
8	COMM2	Inter-cluster communication: Connect to COMM1 of the next cluster's switchgear.
9	POWER	Auxiliary power input.
10	COMM1	Inter-cluster communication: Connect to COMM2 of the previous cluster's switchgear or to the BCP cabinet.
11	COMM3	Intra-cluster communication: Connect to all BMUs in the cluster.
12	P1-	Connect to the DC negative terminal of the copper busbar inside the BCP cabinet.
13	P1+	Connect to the DC positive terminal of the copper busbar inside the BCP cabinet.

## 5.5 BCP Cabinet Electrical Connections

### 5.5.1 BCP Cabinet Auxiliary Power Supply Cable Connection

In accordance with the markings on the auxiliary power copper busbar, use 3 cables with a cross-sectional area of not less than  $25\text{mm}^2$  to connect to the A, B, C, and N interfaces respectively. The ends of the cables must be crimped with terminal lugs matching the M8 bolt hole diameter, and fastened using M8 combination bolts. Tightening torque:  $12\pm 0.5\text{N}\cdot\text{m}$ .

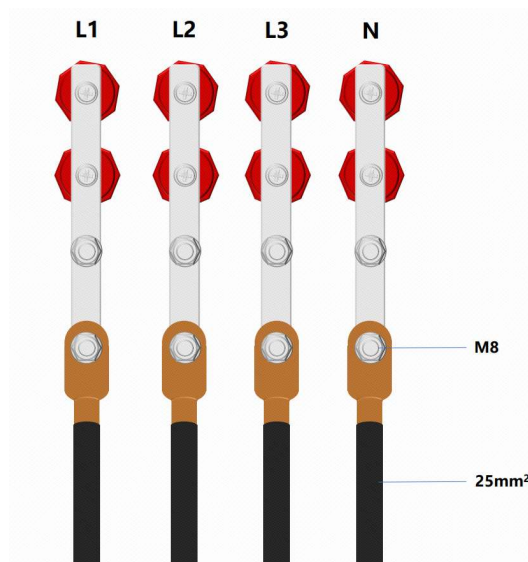

**Auxiliary Power Supply Cable Connection**

### 5.5.2 DC Power Cable Connection

As shown in the figure, use cables to connect all DC+ and DC- interfaces. The ends of the cables must be crimped with terminal lugs matching the M8 bolt hole diameter, and fastened using M8 combination bolts. Tightening torque:  $12\pm 0.5\text{N}\cdot\text{m}$ .

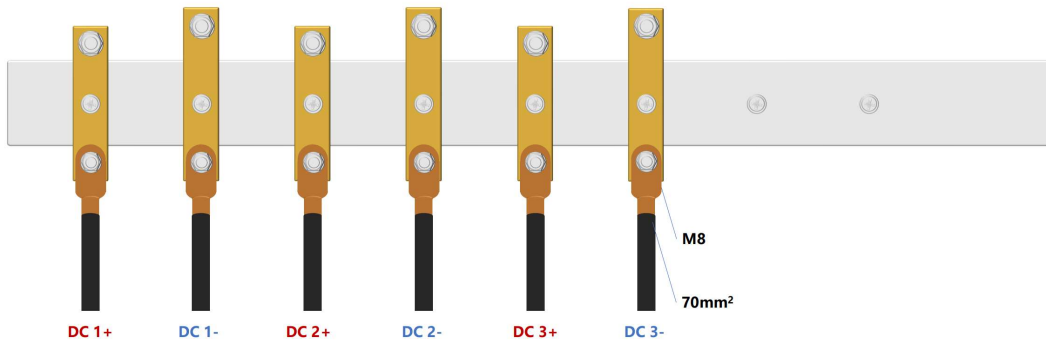

**DC Power Cable Connection**

### 5.5.3 PCS Power Cable Connection

As shown in the figure, use a cable to connect the PCS+ and PCS- interfaces. The end of the cable must be crimped with a terminal lug matching the M12 bolt hole diameter, and fastened using M12 combination bolts. Tightening torque:  $20 \pm 1 \text{N}\cdot\text{m}$ . The recommended cable cross-sectional area is  $240 \text{mm}^2$ .

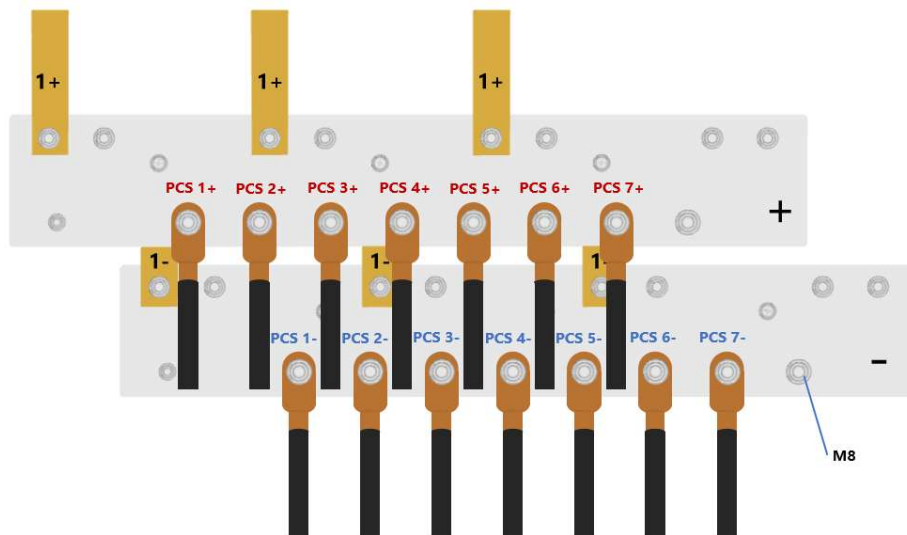

**PCS Power Cable Connection**

## 5.5.4 Battery Cabinet Auxiliary Power Supply Cables and Communication Cables Connection

According to the table below, connect the auxiliary power supply cables and communication cables of the battery cabinet to the corresponding terminals inside the BCP Cabinet.

XT6		ESS#1	
Lower End/-2	Front View	Upper End/-1	
LCU#1:L	1	MCB8:2	
LCU#1:N	2	(PT 6)	MCB8:4
LCU#2:L	3		MCB9:2
LCU#2:N	4		MCB9:4
BMS:L	5	(PT 2.5)	XT5:1-2
BMS:N	6		XT5:6-2
XT7		ESS#2	
Lower End/-2	Front View	Upper End/-1	
LCU#3:L	1	MCB10:2	
LCU#3:N	2	(PT 6)	MCB10:4
LCU#4:L	3		MCB11:2
LCU#4:N	4		MCB11:4
BMS:L	5	(PT 2.5)	XT5:2-2
BMS:N	6		XT5:7-2
XT8		ESS#3	
Lower End/-2	Front View	Upper End/-1	
LCU#5:L	1	MCB12:2	
LCU#5:N	2	(PT 6)	MCB12:4
LCU#6:L	3		MCB13:2
LCU#6:N	4		MCB13:4
BMS:L	5	(PT 2.5)	XT5:3-2
BMS:N	6		XT5:8-2
XT9		ESS#4	
Lower End/-2	Front View	Upper End/-1	
LCU#7:L	1	MCB14:2	
LCU#7:N	2	(PT 6)	MCB14:4
LCU#8:L	3		MCB15:2
LCU#8:N	4		MCB15:4
BMS:L	5	(PT 2.5)	XT5:4-2
BMS:N	6		XT5:9-2

XT10		ESS#5	
Lower End/-2	Front View	Upper End/-1	
LCU#9:L	1	MCB16:2	
LCU#9:N	2	(PT 6)	MCB16:4
LCU#10:L	3		MCB17:2
LCU#10:N	4		MCB17:4
BMS:L	5	(PT 2.5)	XT5:2-1
BMS:N	6		XT5:7-1
XT11		ESS#6	
Lower End/-2	Front View	Upper End/-1	
LCU#11:L	1	MCB18:2	
LCU#11:N	2	(PT 6)	MCB18:4
LCU#12:L	3		MCB19:2
LCU#12:N	4		MCB19:4
BMS:L	5	(PT 2.5)	XT5:3-1
BMS:N	6		XT5:8-1
XT12		ESS#7	
Lower End/-2	Front View	Upper End/-1	
LCU#13:L	1	MCB20:2	
LCU#13:N	2	(PT 6)	MCB20:4
LCU#14:L	3		MCB21:2
LCU#14:N	4		MCB21:4
BMS:L	5	(PT 2.5)	XT5:4-1
BMS:N	6		XT5:9-1
XT13		ESS#8	
Lower End/-2	Front View	Upper End/-1	
LCU#15:L	1	MCB22:2	
LCU#15:N	2	(PT 6)	MCB22:4
LCU#16:L	3		MCB23:2
LCU#16:N	4		MCB23:4
BMS:L	5	(PT 2.5)	XT5:5-1
BMS:N	6		XT5:10-1

XT14		S/G#1:COMM1	
Lower End/-2	Front View	Upper End/-1	
CAN:H	1	(PT 2.5)	BAU:CAN1-4
CAN:L	2		BAU:CAN1-2
CAN:G	3	PE	BAU:CAN1-3
FSS:24V+	4	(PT 2.5)	Sounder Strobe:V
FSS:24V-	5		Sounder Strobe:G
FSS:LOOP+	6		Smoke:L1+
FSS:LOOP-	7		Smoke:L1-
FSS:GND	8	PE	Smoke:GND

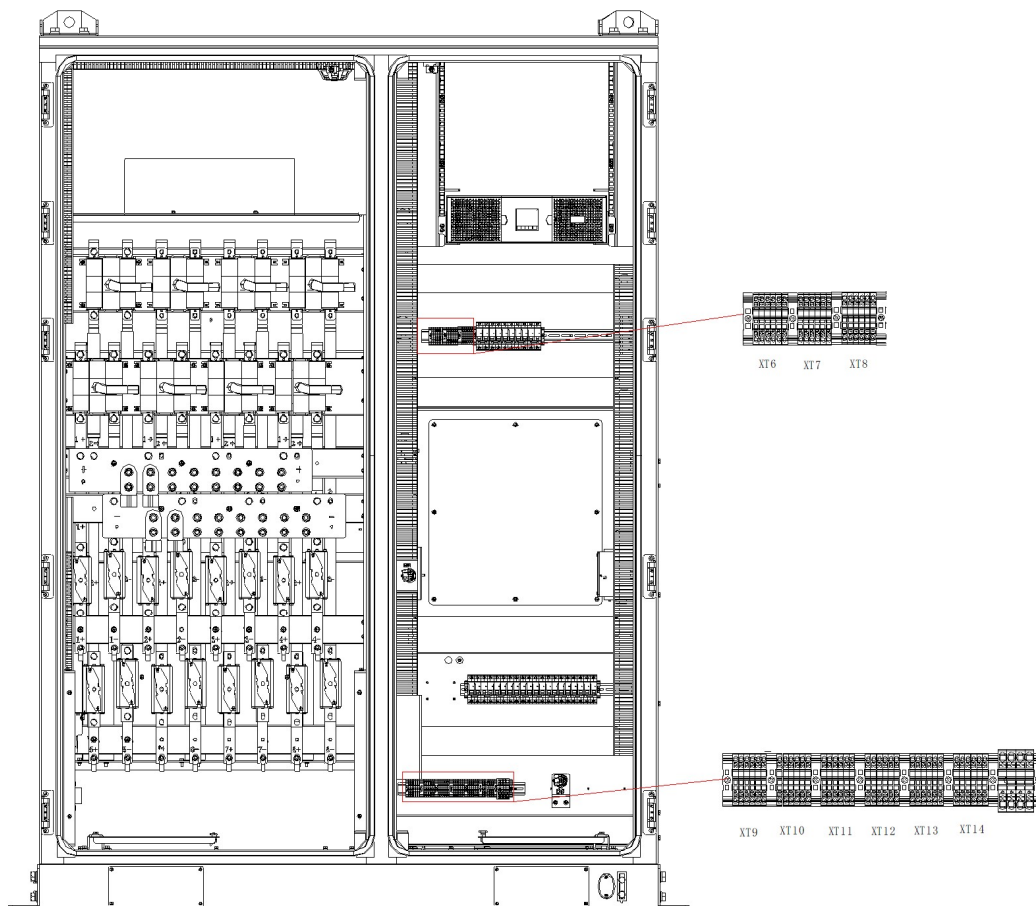

**Terminal Block Position**

## 5.5.5 Ethernet Communication Port Connection

As shown below, the BCP cabinet provides multiple Ethernet communication ports inside. Use network cables to connect them to other devices.

Markings	Name	Description
1	ETH1	Ethernet communication port, connected to Golden Shield.

2	ETH2	Ethernet communication port, connected to BAU.
3	ETH3	Ethernet communication port, connected to EMS.
4	ETH4	System maintenance Ethernet port.
5	ETH5	Reserved Ethernet port.

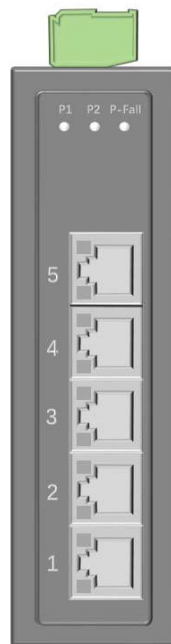

**Ethernet Communication Ports**

## 5.5.6 Reserved Dry Contact Interfaces

Multiple dry contact interfaces are reserved inside the BCP cabinet. Select appropriate cables to connect to the corresponding dry contacts according to actual needs.

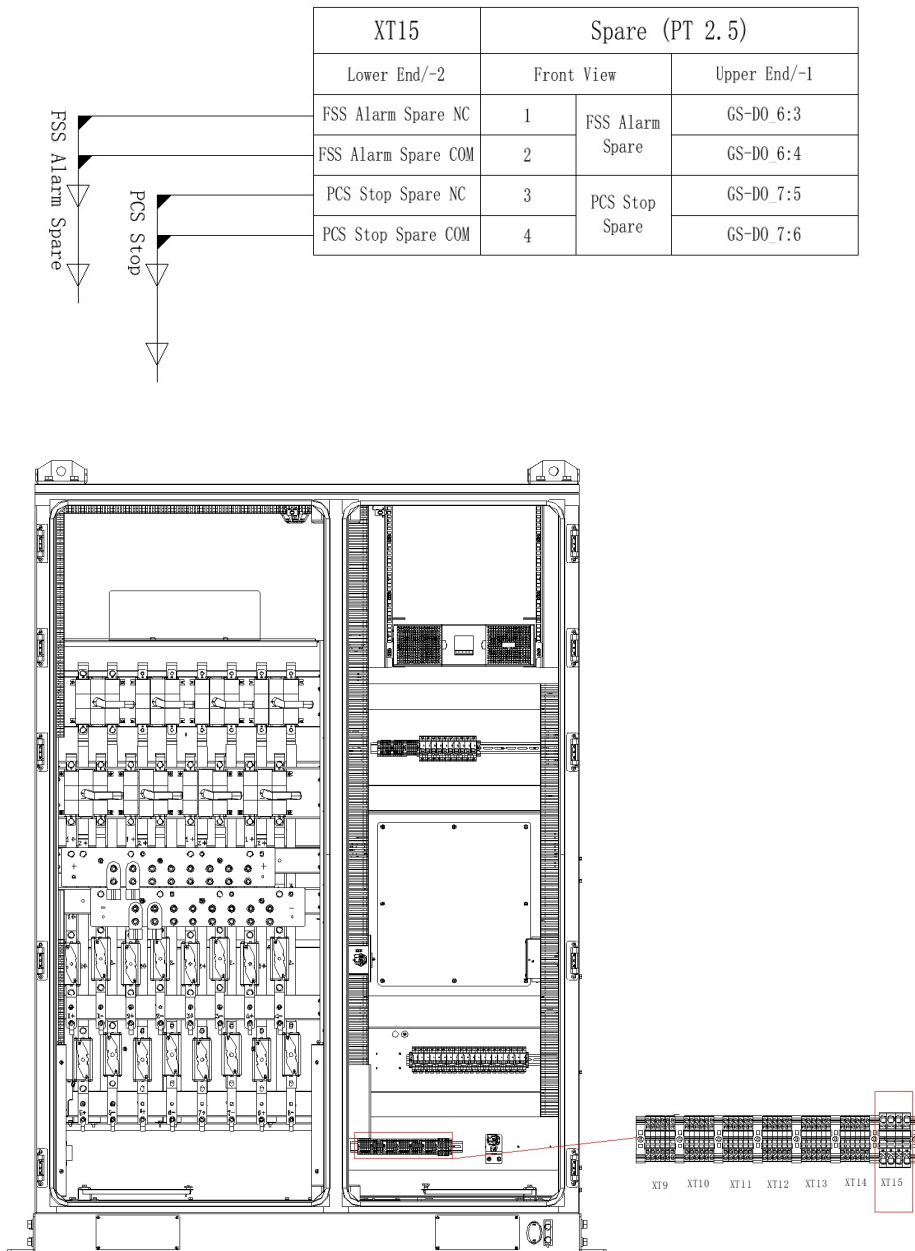

**Terminal Block Position**

## 5.6 MSD Installation

1. The installation position of the MSD is shown in the figure below.



2. Press the latch of the MSD plug and rotate the push rod simultaneously to unlock the push rod.
3. Rotate the push rod until a click sound is heard, indicating that the push rod has reached the pre-installed position.
4. Ensure that the plug and socket housings overlap each other, and insert the plug into the socket.
5. Ensure that the rotating post of the socket fully enters the guide rail and a click sound is heard. Otherwise, the rotating post may break when performing subsequent steps.
6. Rotate the push rod 90°, so that the push rod is parallel to the installation surface.
7. Push in the red CPA button.
8. The MSD installation is complete.
9. Repeat the above steps to install MSD for each battery module.

## 5.7 Post-Connection Inspection

- Check all wiring points to ensure that the cables are firmly connected and there are no missing or loose connections.
- Ensure that the wiring terminals are firmly and reliably connected.

# 6 System Commissioning

---

## 6.1 Precautions

### **WARNING**

- Operations related to system commissioning must be performed by qualified electrical personnel.
- Do not touch any original equipment or metal components before powering on.
- When the product is placed for a long time without formal operation, auxiliary power should be supplied to ensure that the temperature - control and dehumidification equipment (such as liquid - cooled units, air - cooled air conditioners, heaters, dehumidifiers, etc.) operates normally, so as to ensure that the temperature and humidity inside the box meet the requirements, remain dry, and there is no accumulated water.

## 6.2 Pre-Commissioning Inspection

### 6.2.1 Cable Connection

- After checking all wiring points, ensure that no cables are missing or loose.
- Maintain a safe distance and ensure that wiring terminals are firmly and reliably connected.
- Before the FSS system is put into use, ensure that the start - up wire Aerosol - ACT and the feedback wire Aerosol - FEDB of the fire - extinguishing device are in a disconnected state.

### 6.2.2 System Setup

Before powering on, carefully check the following items and ensure all electrical connections comply with this manual's requirements.

- The battery cabinet and BCP cabinet have been effectively grounded.
- The system emergency stop button is in normal condition.
- All circuit breakers in the BCP cabinet are in the "OFF" position.
- Manual Service Disconnects (MSDs) of all battery modules in the battery cabinet are inserted and properly locked.
- Ensure the automatic exhaust valve of the liquid cooling pipeline is in the open position.

## 6.3 Power-On Commissioning

### 6.3.1 Wiring Diagram for Auxiliary Power Supply

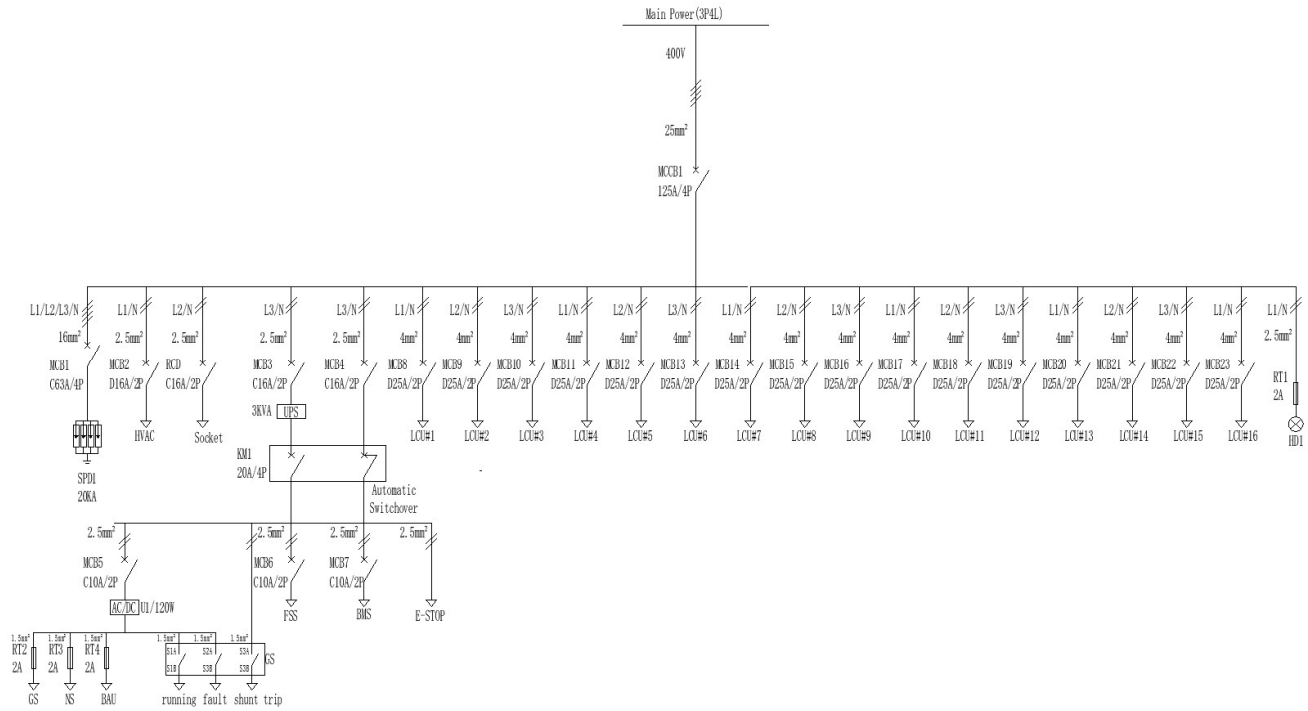

**Wiring Diagram for Auxiliary Power Supply**

### 6.3.2 Circuit Breakers and Control Objects

<b>Circuit Breaker</b>	MCCB1	MCB1	MCB2	RCD
<b>Control Object</b>	400V Power Supply	Surge Protective Device	HVAC	Socket
<b>Circuit Breaker</b>	MCB3	MCB4	MCB5	MCB6
<b>Circuit Breaker</b>				MCB7

UPS	UPS Bypass	Switch Mode Power Supply	FSS	Switchgear
MCB8	MCB9	...	MCB22	MCB23
Liquid Cooling	Liquid Cooling	...	Liquid Cooling	Liquid Cooling
Unit#1	Unit#2		Unit#15	Unit#16

### 6.3.3 Auxiliary Power Supply

1. When powering up the ESS for the first time, ensure the UPS is properly connected to its internal battery, then start the UPS via cold start (battery-powered).
2. Close the MCB5 Switch Mode Power Supply. When DC 24V outputs normally, devices such as GS, network switch, and BAU are powered up.



#### GS-web Maintenance Mode Switch

3. Connect the computer to the GS-web port inside the cabinet or the network switch using a network cable. After changing the computer's IP address to 192.168.1.150, enter

192.168.1.136 in the browser to access the GS-web interface, and switch the GS operation mode from Normal Mode to Maintenance Mode (as shown in the figure above).

**i Note:** Exit the maintenance mode after normal operation. This change will automatically revert to normal mode when the GS is powered down.

4. On the GS-web interface, access the "Aux-device" page and ensure the AC shunt trip is in the "OPEN" state.
5. After the 400V 3P4L power supply is properly connected, measure the voltage between the neutral wire and the ground wire at the line side of the MCCB1. Ensure that the voltage is less than 2V before closing the MCCB1 400V power supply switch.

**i Note:** If the voltage between the neutral wire and the ground wire at the line side of the MCCB1 is greater than or equal to 2V, it is strictly prohibited to close the MCCB1 power supply switch.

6. Close the MCB1 AC surge protective device switch. The AC surge protective device operates normally.
7. Close the MCB2 HVAC power switch. The HVAC is powered normally.
8. Close the MCB3 UPS power switch. The UPS operates normally and switches to utility mode.
9. Close the MCB4 UPS bypass power switch. When the UPS malfunctions, it can be automatically switched to the bypass mode.
10. Open the fire alarm control panel. After completing the 24V backup power connection, close the MCB6 FSS power supply switch, and the fire alarm control panel will be powered

normally.

11. Close the MCB7 switchgear power switch. The switchgears' AC power supply operates normally.
12. Close MCB8~MCB23 in sequence. The liquid cooling units are powered normally.
13. Close the RCD socket power switch. The socket is powered normally.

## 6.3.4 Operational Status Overview

After the auxiliary power supply is powered normally, the operation status information of the energy storage system, all battery clusters, and auxiliary devices such as HVAC can be viewed on the GS-web terminal.

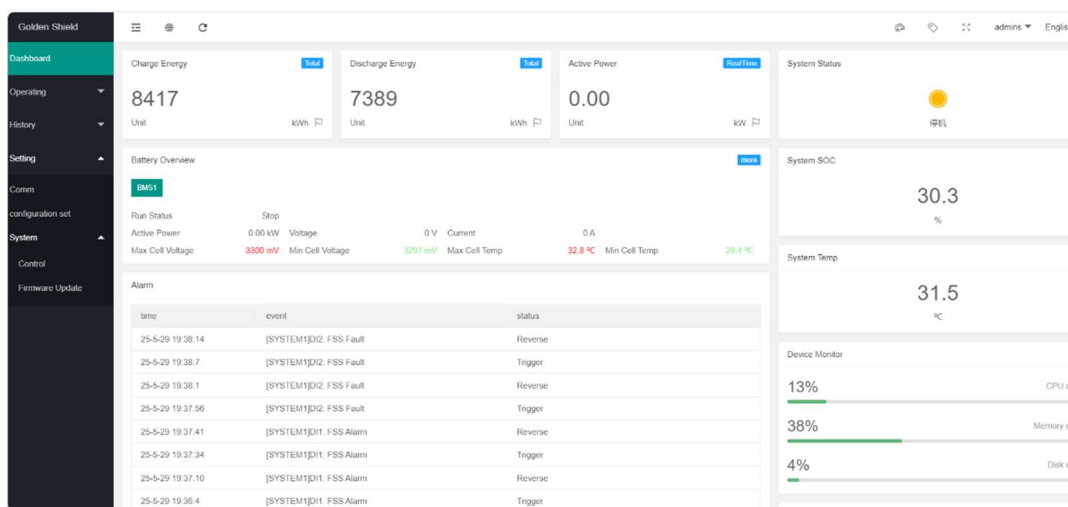

**Operational Status Overview of the ESS**

Rack	Run Status	Chg/Dsg Status	SOC	Voltage	Current
Rack1	StandBy	Idle	30.3 %	1371.6 V	0 A
Rack2	StandBy	Idle	30.3 %	1372.6 V	0 A
Rack3	StandBy	Idle	30.3 %	1372.6 V	0 A
Rack4	Stop	Idle	30.3 %	1372.9 V	0 A
Rack5	StandBy	Idle	30.3 %	1370.9 V	0 A
Rack6	StandBy	Idle	30.3 %	1372.7 V	0 A
Rack7	StandBy	Idle	30.3 %	1371.9 V	0 A
Rack8	StandBy	Idle	30.3 %	1371.9 V	0 A
Rack9	StandBy	Idle	30.3 %	1371.9 V	0 A
Rack10	StandBy	Idle	30.3 %	1371.9 V	0 A
Rack11	StandBy	Idle	30.3 %	1371.9 V	0 A
Rack12	StandBy	Idle	30.3 %	1371.9 V	0 A

**Operational Status Overview of the Battery Clusters**

Device	Run State	Work Mode	Compressor 1 Operating State	Inlet Temp	Outlet Temp	Inlet Pressure	Outlet Pressure	Pump Speed
HVAC1	Off	Cycle	Off	0 °C	0 °C	0 Bar	0 Bar	0 %
HVAC2	On	Cycle	Off	31.6 °C	31.2 °C	1.31 Bar	2.15 Bar	63 %
MasterDehumidifier	Ambient Temperature: 25.5 °C Humidity: 58.9 %RH		Dehumidify Start Setpoint: 64		Dehumidify Stop Setpoint: 44			
SlaveDehumidifier	Ambient Temperature: 25.9 °C Humidity: 59.5 %RH		Dehumidify Start Setpoint(Read Only): 61		Dehumidify Stop Setpoint(Read Only): 41			

**Operational Status Overview of Auxiliary Devices**

### 6.3.5 High-Voltage DC Power On/Off Operations

**i NOTE**

- When the energy storage system is in standby state under non-maintenance mode, charging and discharging operations cannot be performed.

- When the energy storage system is in operation state, the active power and reactive power parameters of PCS will be automatically set to 0.

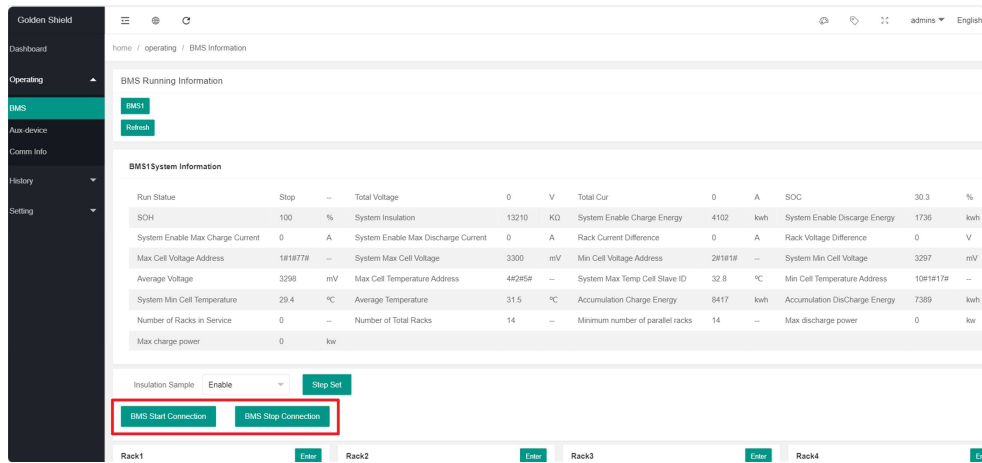

## BMS Real-time Operational Information

When communication is normal and there are no alarms, perform high-voltage DC power on/off operations via the GS web interface, as shown in figure above.

- Close the isolating switches inside the BCP cabinet. Click the "BMS Start Connection" button. All contactors in the switchgear of battery clusters will close, completing the DC side power-on. The battery system is now in a charge/discharge enabled state.
- Click the "BMS Stop Connection" button. All contactors in the switchgear of battery clusters will open, completing the DC side power-off. The battery system cannot perform charge/discharge operations at this time. Open the isolating switches inside the BCP cabinet.

**i Note:** During charging or discharging, do not manually turn off the energy storage system.

Failure to follow this instruction may damage contactors or isolating switches.

## 6.3.6 Powering Off the Auxiliary Power Supply

1. Disconnect RCD.
2. Disconnect MCB8~MCB23 in sequence.
3. Disconnect MCB5, MCB6 and MCB7.
4. Disconnect MCB2.
5. Disconnect MCB3 and MCB4.
6. Disconnect MCB1 and MCCB1.

# 7 System Maintenance

---

## 7.1 Precautions

 **DANGER**

Before performing system maintenance, carefully read and strictly follow the safety precautions listed in Section [1.7 Maintenance and Replacement](#).

### Declaration

- The maintenance cycles mentioned in this manual are the minimum requirements. If the Authority Having Jurisdiction (AHJ) at the project location specifies more stringent cycle requirements, its regulations shall be complied with.
- This chapter does not fully and exhaustively describe all system maintenance requirements. Applicable maintenance management systems shall be developed in compliance with the laws, regulations, and standards of the country or region where the project is located.
- The system maintenance content described in this chapter is for reference only. In case of

discrepancies between the maintenance specifications provided by the equipment manufacturer and the content of this chapter, the maintenance specifications provided by the equipment manufacturer shall take precedence.

## Maintenance Personnel

### NOTICE

- Personnel responsible for operating and maintaining the equipment must undergo rigorous training, understand all safety precautions, master correct operation and maintenance methods, and possess the knowledge and experience required for maintaining relevant equipment.
- Only qualified professionals or trained personnel are permitted to operate and maintain the equipment.
- Only qualified professionals are allowed to remove safety devices and overhaul equipment.
- Replacement of equipment and components (including software) must be performed by qualified professionals or authorized personnel.

Qualified maintenance personnel shall meet any of the following requirements:

- Have received training provided by the manufacturer and obtained a certification for the relevant equipment issued by the manufacturer.
- Have obtained relevant certifications from an accredited certification body accepted and

recognized by the AHJ.

- Are registered, licensed, or certified by the authorities of the country or region where the project is located to service the relevant equipment.

## 7.2 Battery System Maintenance

### 7.2.1 Precautions

#### **WARNING**

- Incorrect operation may lead to serious personal injury or property damage.
- Be cautious of hazardous voltages in battery modules and be aware of the risk of short circuits.
- If a rapid temperature rise in cells is detected, cease operation immediately and seek assistance promptly.
- In the event of emergencies such as short circuits, fires, or electric shocks, remain calm, stop charging immediately, apply appropriate emergency measures, and seek professional help.

#### **CAUTION**

- Ensure a dry and well-ventilated environment is selected, and operations are conducted in designated areas.
- Keep the work area free of debris, especially metal fragments or liquids that

may cause short circuits.

- Verify that the balancer settings match the cell recharging requirements.
- Before performing recharging operations, inspect the external condition of cells for damage, dents, swelling, or liquid leakage.
- When charging battery modules, never wear metal jewelry like necklaces, rings, or watches.



## NOTICE

- Conduct safety training for operators in advance to familiarize personnel with the chemical properties and potential risks of cells, and understand emergency handling procedures.
- When temporarily storing cells, handle them with care to avoid impact, extrusion, or puncture. Terminals must be protected to prevent positive-negative short circuits.
- Regularly inspect and maintain equipment related to cell use to ensure normal operation. If cell issues or equipment damage are detected, take appropriate measures immediately (e.g., discontinue use, repair, or replacement).
- Follow the instructions strictly during operations to ensure compliance with specifications at every step.
- At least two personnel must be present during maintenance, and all must

wear PPE.

- Long-term storage of energy storage systems without use may cause irreversible battery damage. Ensure regular maintenance!

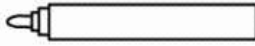
## 7.2.2 Tools and Instruments

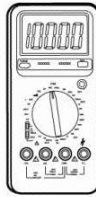
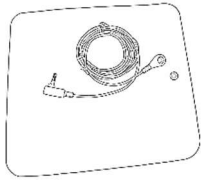
Name	Purpose	Image
Electric Screwdriver Kit	For battery module installation and removal.	
Marker Pen and Labels	For recording inspection and maintenance dates.	
Utility Knife	For removing outer packaging.	
Multimeter (0.1mV precision)	For measuring insulation resistance, voltage, AC internal resistance, and other data.	
Grounding Mat	For electrostatic protection.	

**Charger** For charging, discharging, and voltage balancing of batteries.

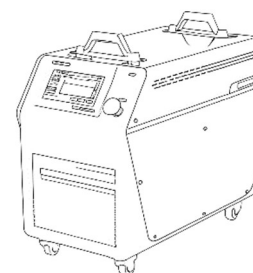

**Fire Extinguisher** For preventing thermal runaway in LFP batteries due to short circuits.

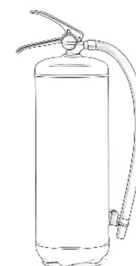





## Recommended Charger Specifications

Parameter Name	Value
Input Voltage	AC 100~240V
	50/60Hz
Operating Temperature Range	-10~40°C
Operating Humidity Range	< 80% RH
Storage Temperature Range	-20~80°C
Storage Humidity Range	< 80% RH
Charging Mode	Supports constant current charging mode
DC Output Voltage Range	0~500V
DC Output Current Range	0~200A

Voltage Stability	$\leq 0.2\%$
Current Stability	$\leq 0.5\%$
Load Stability	$\leq 0.5\%$
Ripple and Noise	$\leq 1\%$ (RMS)
Display Accuracy	$\pm 0.5\%$
(Optional) Human-Machine Interface	Charging voltage, charging current, charging capacity, charging time, and other data can be read from the charging interface.

## 7.2.3 Personal Protective Equipment

Name	Purpose	Image
Protective Clothing	For electrical insulation protection.	
Insulating Gloves	For electrical insulation protection.	
Insulating Shoes	For electrical insulation protection.	
Safety Goggles	For arc flash protection.	

Safety Helmet

For head protection.

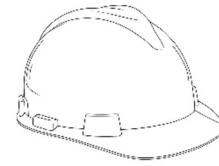

Anti-static Wrist

For electrostatic protection.

Strap



---

**i Note:** Personal protective equipment of Category 1 or higher shall be worn.

---

## 7.2.4 Terminology

- **Normal Operation:** Refers to the continuous and alarm-free operation of the system in accordance with the conditions agreed upon in the agreement.
- **Intermittent Operation:** Indicates that the operating frequency of the system is not fixed, and a continuous operation cannot be guaranteed.
- **Long-term Idle Operation:** Refers to the system not being started and operated for more than six consecutive months.
- **Voltage Difference at the End of Charging/Discharging:** Refers to the voltage difference between the cell with the highest voltage and the cell with the lowest voltage within the battery system or battery module when charged/discharged to its maximum/minimum cutoff voltage.
- **A Full Charge-Discharge Cycle:** Refers to the cycle in which the battery system or battery module is first charged to its maximum cut-off voltage and then discharged to its minimum cut-off voltage.

- **Round-trip Efficiency:** The ratio of discharge energy to charging energy, typically expressed as a percentage.
- **Spare Battery Module:** Refers to the battery modules independently purchased by customers from Risen Storage and not pre-installed in energy storage systems.

## 7.2.5 Maintenance Requirements

### System in Normal Operation

- The system must undergo an SOC calibration and voltage balancing, with voltages adjusted to the normal range prior to its first operation.
- Conduct charge-discharge activation on the system once every 12 months to prevent potential battery damage.
- Perform routine inspection of the system once every 12 months, maintain detailed inspection records, and promptly address any detected abnormal conditions.
- If the system operates in a shallow charging and discharging state continuously for more than 6 months (i.e., the state of charge (SOC) is not 0% at the end of discharge and not 100% at the end of charge), an SOC calibration must be performed for the system.

### System in Intermittent Operation

- For a system unused within six consecutive months, conduct a charge-discharge activation when restarting to prevent potential battery damage.
- When the system remains unused for more than 6 consecutive months, adjust its SOC to

30%~50% before storage and promptly disconnect all power-consuming devices.

- Perform routine inspection of the system once every 3 months, maintain detailed inspection records, and promptly address any detected abnormal conditions.
- Conduct charge-discharge activation on the system once every 3 months to prevent potential battery damage.
- Before reusing a system that has been unused for an extended period, it must undergo at least one charge-discharge activation to activate the battery and restore it to optimal performance.

## **System in Long-term Idle Operation**

- When the system has no immediate plans for use or will transition to an unused state, adjust its SOC to 30%~50% before storage and promptly disconnect all power-consuming devices.
- Perform routine inspection of the system once every 3 months, maintain detailed inspection records, and promptly address any detected abnormal conditions.
- Conduct charge-discharge activation on the system once every 3 months to prevent potential battery damage.
- Before reusing a system that has been unused for an extended period, it must undergo at least one charge-discharge activation to activate the battery and restore it to optimal performance.
- Before reusing a system that has been unused for an extended period, an SOC calibration

must be performed on the system.

## Spare Battery Modules

- Perform routine inspection of the spare parts once every 3 months, maintain detailed inspection records, and promptly address any detected abnormal conditions.
- Perform charge-discharge activation on the spare battery modules once every 6 months.
- The recommended SOC for long-term storage of spare battery modules is 30%~50%.

### 7.2.6 Inspection Items

Item	Checklist
Power-On Check	Check all devices and the host computer interface, record parameters such as total voltage, individual cell voltage, cell temperature, cell voltage difference, etc., and observe for any anomalies.

### 7.2.7 Abnormal Condition Handling

	Abnormal Condition	Handling Solution
<b>Battery System</b>	An abnormal voltage difference among cells is detected at the end of charging/discharging in the battery system.	Perform voltage balancing until the voltage difference at the end of charging/discharging for all cells in the system meets the requirements.
	The voltage of any single cell in	The battery module containing the cell may

the battery system is lower than 2V.

be permanently damaged. Contact the after-sales service promptly for handling. For contact information, refer to Chapter 9 Technical Support and After-Sales Service.

Cell temperature within the battery module exceeds the average temperature by 5°C or more during charging/discharging.

1. Inspect the cell temperature acquisition harness for aging, disconnection, damage, pin retraction, cold solder joints, etc. If any issues are found, repair or replace the harness.
2. Check the AC internal resistance of the cell at 1kHz AC frequency and 30% SOC, and verify that the measured value is less than 1.8mΩ. If the measured value is greater than or equal to 1.8mΩ, the entire battery module containing the abnormal cell shall be replaced.

**Spare Battery Modules** The voltage of any single cell in the battery module is lower than 2V.

1. The module may be permanently damaged. Contact the after-sales service promptly for handling. For contact information, refer to Chapter 9 Technical Support and After-Sales Service.

2. Repack the module completely in its original packaging and store it in a separate area to avoid placing it together with functional modules.

---

The voltage of any single cell in the battery module is 2~3V (inclusive).

1. Conduct charge-discharge activation on the battery module.
2. If an abnormal voltage difference among cells at the end of charging/discharging is detected in the battery module, perform voltage balancing until the voltage difference at the end of charging/discharging for all cells in the module meets the requirements.

---

Cell temperature within the battery module differs from the average temperature by 5°C or more.

1. Inspect the cell temperature acquisition harness for aging, disconnection, damage, pin retraction, cold solder joints, etc. If any issues are found, repair or replace the harness.
  2. Check the AC internal resistance of the cell at 1kHz AC frequency and 30% SOC, and verify that the measured value is less
-

than 1.8mΩ. If the measured value is greater than or equal to 1.8mΩ, the entire battery module containing the abnormal cell shall be replaced.

## 7.2.8 Pre-Maintenance Checks

Item	Checklist
Wiring Harness Check	Inspect the wiring harness for aging, disconnection, damage, pin retraction, cold solder joints, etc. If any issues are found, repair or replace the harness.
Insulation Check	Use an insulation meter to test the insulation resistance between the positive/negative terminals and the grounding point. The insulation resistance of the battery module must be greater than 10MΩ. If it is less than or equal to 10MΩ, immediately stop all subsequent operations and contact the after-sales service for handling. For contact information, refer to Chapter <a href="#">9 Technical Support and After-Sales Service</a> .

## 7.2.9 Charge-Discharge Activation

### Steps

1. Discharge the battery system or spare battery modules at 0.25P until reaching the cut-off voltage.
2. Stand idle for a duration adjusted based on actual conditions.

3. Charge the battery system or spare battery modules at 0.25P until reaching the cut-off voltage.
4. Stand idle for a duration adjusted based on actual conditions.
5. Discharge the battery system or spare battery modules at 0.25P until reaching the cut-off voltage.
6. Stand idle for a duration adjusted based on actual conditions.
7. Charge the battery system or spare battery modules at 0.25P until the SOC reaches 30%~50%.

## 7.2.10 Voltage Balancing

### Spare Battery Modules

- When the voltage difference at the end of charging among the cells in the battery module is  $\leq 250$  mV, it is within the normal range, and no voltage balancing is required. When the voltage difference at the end of charging does not meet the above conditions, perform the following voltage balancing steps:
  1. Perform a full charge on the battery module at rated power until the voltage reaches the maximum protection value, then stop. Record the voltage data of all cells in the battery module at the moment of charging termination.
  2. Allow the battery cluster to stand idle for 30 minutes after charging termination.
  3. Export the recorded voltage data at the moment of charging termination and compile it into a table. Use a scatter plot to identify the serial numbers and quantity of cells

with voltage differences exceeding the normal range, then perform individual charging on each out-of-range cell one by one.

4. For all high-voltage cells (i.e., cells with a voltage difference at the end of charging  $\geq 250$  mV), use a balancer to discharge them at a constant current of 2.5A until their voltage drops to 30 mV below the average voltage of non-high-voltage cells in the battery module. After discharging, let the cells stand idle for 30 minutes.
  5. Continue charging the battery module at rated power until the voltage reaches the maximum protection value, then stop. Re-collect and evaluate the voltage data at the moment of charging termination to verify the balancing effect. If any cell still has a voltage difference at the end of charging  $\geq 250$  mV, repeat Step 4 and continue charging until all cells in the battery module have a voltage difference at the end of charging  $< 250$  mV. The balancing process is then completed.
  6. After confirming that the voltage differences at the end of charging of all cells in the battery module meet the requirements, perform a full charge-discharge cycle at rated power. Then, verify the charge-discharge energy data to ensure they comply with the standards specified in the technical agreement.
- When the voltage difference at the end of discharging among cells in the battery module is  $\leq 300$  mV, no voltage balancing is required. If the voltage difference at the end of discharging does not meet the above conditions, perform the following voltage balancing steps:
    1. Perform a full discharge on the battery module at rated power until the voltage

reaches the minimum protection value, then stop. Record the voltage data of all cells in the battery module at the moment of discharging termination.

2. Allow the battery cluster to stand idle for 30 minutes after discharging termination.
3. Export the recorded voltage data at the moment of discharging termination and compile it into a table. Use a scatter plot to identify the serial numbers and quantity of cells with voltage differences exceeding the normal range, then perform individual charging on each out-of-range cell one by one.
4. For all low-voltage cells (i.e., cells with a voltage difference at the end of discharge  $\geq 300$  mV), use an equalizer to charge them at a constant current of 2.5A until their voltage exceeds the average voltage of non-low-voltage cells in the battery module by 30 mV. After charging, let the cells stand idle for 30 minutes.
5. Continue to fully discharge the battery module at rated power until the voltage reaches the minimum protection value, then stop. Re-collect and evaluate the voltage data at the moment of discharge termination to confirm the balancing effect. If any cell still has a voltage difference at the end of discharging  $\geq 300$  mV, repeat Step 4 and continue individual charging until all cells in the battery module have a voltage difference at the end of discharging  $< 300$  mV.
6. After confirming that the voltage differences at the end of discharge of all cells in the battery module meet the requirements, perform a full charge-discharge cycle at rated power. Then, verify the charge-discharge energy data to ensure they comply with the standards specified in the technical agreement.

## Battery System

- When the voltage difference at the end of charging among cells in the system is  $\leq 380$  mV, it is within the normal range, and no voltage balancing is required. If the voltage difference at the end of charging does not meet the above conditions, perform the following voltage balancing steps:
  1. Perform a full charge on the system at rated power until the voltage reaches the maximum protection value, then stop. Record the voltage data of all cells in the system at the moment of charging termination.
  2. Allow the battery system to stand idle for 30 minutes after charging termination.
  3. Export the recorded voltage data at the moment of charging termination and compile it into a table. Then, use a scatter plot to confirm the numbers and quantity of the cells whose voltage differences exceed the normal range. Next, charge the out-of-range single cells one by one.
  4. For all high-voltage cells (i.e., cells with a voltage difference at the end of charging  $\geq 380$  mV), use a balancer to discharge them at a constant current of 2.5A until their voltage drops to 30 mV below the average voltage of non-high-voltage cells in the system. After discharging, let the cells stand idle for 30 minutes.
  5. Continue charging the system at rated power until the voltage reaches the maximum protection value, then stop. Re-collect and evaluate the voltage data at the moment of charging termination to confirm the balancing effect. If any cell still has a voltage difference at the end of charging  $\geq 380$  mV, repeat Step 4 and continue individual

charging until all cells in the system have a voltage difference at the end of charging <380 mV.

6. After confirming that the voltage differences at the end of charging of all cells in the system meet the requirements, perform a full charge-discharge cycle at rated power. Then, verify the charge-discharge energy data to ensure they comply with the standards specified in the technical agreement.

- When the voltage difference at the end of discharging among cells in the system is  $\leq 480$  mV, it is within the normal range, and no voltage balancing is required. When the voltage difference at the end of discharging is  $> 480$  mV, and the discharge energy and round-trip efficiency meet the requirements of the technical agreement, voltage balancing may not be performed. If the voltage difference at the end of discharging does not meet any of the above conditions, perform the following voltage balancing steps:

1. Perform a full discharge on the system at rated power until the voltage reaches the minimum protection value, then stop. Record the voltage data of all cells in the system at the moment of discharging termination.
2. Allow the battery system to stand idle for 30 minutes after discharging termination.
3. Export the recorded voltage data at the moment of discharging termination and compile it into a table. Then, use a scatter plot to confirm the numbers and quantity of the cells whose voltage differences exceed the normal range. Next, charge the out-of-range single cells one by one.
4. For all low-voltage cells (i.e., cells with a voltage difference at the end of discharge  $\geq$

480 mV), use a balancer to charge them at a constant current of 2.5A until their voltage exceeds the average voltage of non-low-voltage cells in the system by 30 mV.

After charging, allow the cells to stand idle for 30 minutes.

5. Continue discharging the system at rated power until the voltage reaches the minimum protection value, then stop. Re-collect and evaluate the voltage data at the moment of discharge termination to confirm the equalization effect. If any cell still has a voltage difference at the end of discharge  $\geq 480$  mV, repeat Step 4 and continue individual charging until all cells in the system have a voltage difference at the end of discharge  $< 480$  mV.
6. After confirming that the voltage differences at the end of discharge of all cells in the system meet the requirements, perform a full charge-discharge cycle at rated power. Then, verify the charge-discharge energy data to ensure they comply with the standards specified in the technical agreement.

## 7.2.11 SOC Calibration

### Steps

1. Discharge the battery system at rated power until reaching the cut-off voltage.
2. Stand idle for a duration adjusted according to actual conditions. The recommended idle time is greater than 1 hour.
3. Charge the battery system at rated power until reaching the cut-off voltage.

## 7.3 Fire Suppression System Maintenance

### NOTICE

When all the joint commissioning tests of the FSS system are completed and it is about to be put into operation, the following operations need to be carried out:

- Power on both the main power supply and the backup power supply. Wait for 5 minutes until the fire - fighting system runs normally. Measure the output voltage of the starting wires of the fire - extinguishing device, Aerosol - ACT+ and Aerosol - ACT-. The normal output voltage should be approximately 0V (operation is prohibited when there is voltage). Then power off again.
- Insert the connector of the starting wire Aerosol - ACT into the connector of the red - wire end of the aerosol, and insert the connector of the feedback wire Aerosol - FEDB into the connector of the black - wire end of the aerosol. Then power on again.
- Power on again.

### NOTE

- The maintenance cycles below are for reference only. The actual maintenance cycles shall be adjusted according to the natural environment at the project location. If the natural environment is harsh, the maintenance cycles should be shortened.



- To ensure the normal operation of the detector, it should be replaced promptly after it reaches the service life specified by the manufacturer.

## NOTE

When the energy storage system is in long-term storage, the battery of the fire suppression system needs to be regularly charged according to the ambient temperature.

- Storage ambient temperature:  $-20\sim 40^{\circ}\text{C}$ , recommended storage ambient temperature:  $20\sim 30^{\circ}\text{C}$ .
- Recharging cycle: below  $25^{\circ}\text{C}$  (once every six months),  $25\sim 30^{\circ}\text{C}$  (once every four months),  $30\sim 35^{\circ}\text{C}$  (once every three months),  $35\sim 40^{\circ}\text{C}$  (once every two months).
- Maximum storage time: 18 months (at  $25^{\circ}\text{C}$ ).

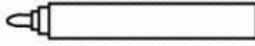
### 7.3.1 Tools and Instruments

Name	Purpose	Image
Marker Pen and Labels	For recording inspection and maintenance dates.	
Screwdriver and Socket Set	For installation and removal of components.	

Brush For removing dust.

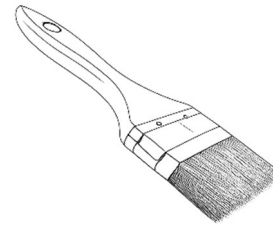

Air Blower For blowing away dust.

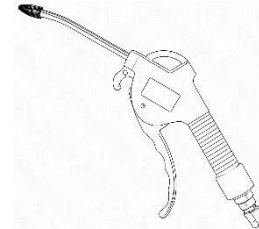

High-Purity  
Alcohol/Non-  
Corrosive Cleaner For removing stubborn dirt.



## 7.3.2 Maintenance Items

Item	Frequency	Checklist	Abnormal Condition Handling
FSS air inlet	Every 6 months	Visual inspection for deformation or damage.	Repair or replace deformed and damaged FSS air inlets.
		Check for dirt, dust, or blockages.	Remove dirt, dust, and blockages.
FSS exhaust fan	Every 6 months	Visual inspection for deformation or damage.	Repair or replace deformed and damaged FSS exhaust fans.
		Check for dirt, dust, or blockages.	Remove dirt, dust, and blockages.

Smoke Detector	Every 6 months	Visual inspection for deformation or damage.	Repair or replace detectors with
		Observe whether the status indicator light is in normal working condition.	physical damage or abnormal operation.
		Check for dirt, dust, or blockages.	Remove dirt, dust, and blockages.
Heat detector	Every 6 months	Visual inspection for deformation or damage.	Repair or replace detectors with
		Observe whether the status indicator light is in normal working condition.	physical damage or abnormal operation.
		Check for dirt, dust, or blockages.	Remove dirt, dust, and blockages.
Combustible Gas Detector	Every 6 months	Visual inspection for deformation or damage.	Repair or replace detectors with
		Conduct a functional check and calibrate if necessary.	physical damage or abnormal operation.
		Check for dirt, dust, or blockages.	Remove dirt, dust, and blockages.



FSS Water Supply Port	Every 12 months	Visual inspection for deformation or damage.	Repair or replace the deformed and damaged FSS water supply port.
-----------------------	-----------------	--	---

## 7.4 Thermal Management System Maintenance

**i NOTE**

The maintenance cycles below are for reference only. The actual maintenance cycles shall be adjusted according to the natural environment at the project location. If the natural environment is harsh, the maintenance cycles should be shortened.

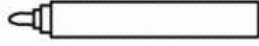
### 7.4.1 Tools and Instruments

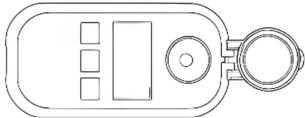
Name	Purpose	Image
Marker Pen and Labels	For recording inspection and maintenance dates.	
Screwdriver and Socket Set	For installation and removal of components.	
Coolant Tester	For checking the concentration of coolant.	

Air Pressure Gauge For measuring air pressure.

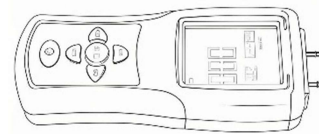

Clean Cloth For wiping dirt.

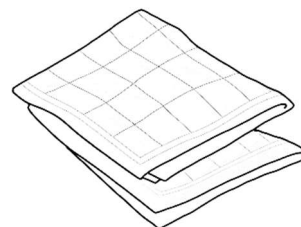

For cleaning dust from the condenser.

**i Note:**

Low-pressure water gun

- The water pressure must be below 2.2 Mpa to avoid damaging the condenser fins.
- It is not recommended to use the water gun to rinse other components.

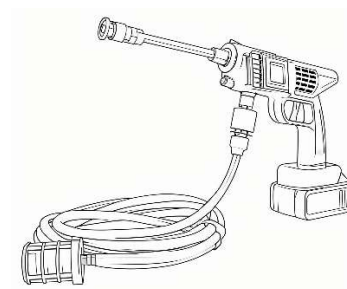

Brush For removing dust.

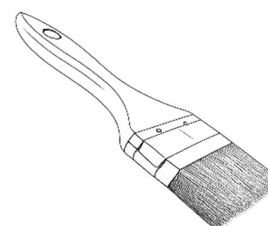

Air Blower For blowing away dust.

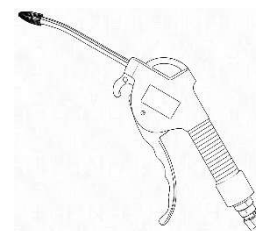

Vacuum cleaner For removing dust.



Fin comb For straightening fins.

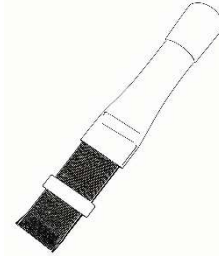

High-Purity Alcohol/Non-Corrosive Cleaner For removing stubborn dirt.



## 7.4.2 Daily Maintenance

Item	Checklist	Inspection Method	Abnormal Condition Handling
Operating Data	The current, voltage, inlet and outlet coolant temperature/pressure and other data during chiller operation.	Visual inspection	The inlet and outlet coolant temperature and pressure can be viewed and obtained via the HMI. In case of abnormal data, please locate the fault and handle it according to Section <a href="#">8.3.4 Liquid Cooling System Fault</a> .
Running	The chiller operates	Visual and	In case of abnormal operation, please

Sound	without abnormal vibration and noise. Mainly observe the operation of the following parts:	auditory inspection	locate the fault and handle it according to Section <a href="#">8.3.4 Liquid Cooling System Fault</a> .
	<ul style="list-style-type: none"> <li>● Compressor</li> <li>● Fan</li> <li>● Circulating water pump</li> </ul>		

Pipeline Reliability	The refrigeration system has no refrigerant leakage. The coolant circulation system has no leakage.	Visual inspection	When a leak is detected, promptly contact the after-sales service for repairs. For contact information, refer to Chapter <a href="#">9 Technical Support and After-Sales Service</a> .
----------------------	---	-------------------	--

Chiller Appearance	The chiller is clean and dust-free and free of dirt.	Visual inspection	After powering off for at least 1 minute, use a brush or cotton cloth to remove dust and dirt from the unit.
--------------------	--	-------------------	--

## 7.4.3 Regular Maintenance

### 7.4.3.1 Filter Screen Maintenance

Item	Checklist	Frequency	Inspection	Abnormal Condition
------	-----------	-----------	------------	--------------------

			Method	Handling
Filter Screen Cleaning	The filter screen shall be free of dust accumulation, foreign object blockage and damage.	Every month	Visual inspection	After powering off for at least 1 minute, use a brush to remove dust and other dirt blockages, or rinse with clean water and let it dry in a cool place.

### 7.4.3.2 Fan Maintenance

Item	Checklist	Frequency	Inspection Method	Abnormal Handling	Condition
Operationa I Reliability of Fan	There is no dust in the fan and no foreign matter blockage at the tuyere.  The fan blades are not damaged, and the fan rotates smoothly without abnormal noise.	Every 6 months	Visual inspection	Clean up the dust with a brush after 1 min of power off. Clean the foreign matters at the tuyere.  After power off for at least 1 min, fasten the fixing screws of the fan and check whether there is any	

internal cable or other objects interfering with the rotation of the fan.

If the fan fails, please replace it.

### 7.4.3.3 Electric Control System Maintenance

Item	Checklist	Frequency	Inspection Method	Abnormal Condition Handling
Reliability of Power	No looseness of electrical cables and terminals.			Tighten the loose cables with a screwdriver after 1 min of power off.
Cable and Power Terminal of Wiring	There is no aging, damage, abnormal heating and other abnormalities in the power cable.	Every 6 months	Visual inspection	Replace the power cables after 1 min of power off.
Panel	There is no dust at the wiring panel.			Clean up the dust with a brush after 1 min of power off.

## 7.4.3.4 Condenser Maintenance

<b>⚠ NOTICE</b>
The edges of the condenser blades are sharp. Please wear gloves during maintenance.

Item	Checklist	Frequency	Inspection Method	Abnormal Condition Handling
Condenser Cleaning	Condenser is free from dust and foreign matter blockage.	Every 6 months	Visual inspection	Clean the condenser with air blower or a vacuum with a brush head after at least 1 min of power off.
	Fins are not seriously deformed.			Use tools such as a fin comb to correct it after at least 1 min of power off.

## 7.4.3.5 Expansion Tank Maintenance

Item	Checklist	Frequency	Inspection Method	Abnormal Condition Handling
------	-----------	-----------	-------------------	-----------------------------

Operating Nitrogen Pressure	The nitrogen pressure is maintained at 0.3~0.4 bar.	Maintain when system faults occur	Air pressure gauge	Fill the expansion tank with nitrogen after at least 1 min of power off.
-----------------------------	---	-----------------------------------	--------------------	--

### Air Pressure Measurement Steps

1. After cutting off the power and waiting for at least 1 min, drain the coolant.
2. Remove the expansion tank maintenance cover plate on the top of the chiller.
3. Unscrew the end cover and use an air pressure gauge to check the pressure of the expansion tank.  
When the pressure is below 0.3 bar, nitrogen needs to be filled to increase the pressure to stabilize at 0.3~0.4 bar.
4. Restore the end cover and replenish the coolant.

### 7.4.3.6 Coolant Maintenance

Item	Checklist	Frequency	Inspection Method	Abnormal Condition Handling
Coolant	<ul style="list-style-type: none"> <li>Concentration meets range requirements</li> <li>The PH value and the concentration of each</li> </ul>	Every 6 months	Coolant tester and visual inspection	Replace the coolant at least 1 minute after power off.

electrolyte meet the

requirements.

- No dirt, precipitation, algae, etc.

## Coolant Specification Requirements

Color	Odor	PH@20°C	Conductivity@25°C	Reserve alkalinity	Turbidity
Blue	No irritating odor	7.5~9.5	2000~4000 $\mu$ S/cm	>1.5 mL	<5 NTU

Cu	Al	Fe	Si	Chlorine ion	Sulfate ions	Total hardness
<5 mg/L	<5 mg/L	<5 mg/L	<10 mg/L	<20 mg/L	<50 mg/L	<20 mg/L

## Coolant Replacement Steps

1. Cut off the power and wait at least 1 minute.
2. Use a drain hose to connect the drain port.
3. Open the ball valves at the coolant drain port to drain the coolant to the coolant storage tank.

After draining, close the valve and remove the drain pipe.

4. Add the coolant, check the PH value and electrolyte concentration of the coolant.
5. After the coolant replenishment is completed, close the ball valve at the coolant filling port and remove the pipe.

### 7.4.3.7 Pipeline Maintenance



Item	Checklist	Frequency	Inspection Method	Abnormal Condition Handling
Pipeline Appearance	Appearance without damage, deformation, or corrosion.	Every 6 months	Visual inspection	After power-off for at least 1 minute, drain the coolant and replace the corresponding pipeline.
Pipeline Reliability	The pipeline is fixed and the connection joints are not loose.	Every 6 months	Visual inspection	After powering off for at least 1 minute, tighten the loose part.
Valve Reliability	No failure or damage to valve components.	Every 6 months	Visual inspection	After power-off for at least 1 minute, drain the coolant and replace the corresponding valve components.

## 7.5 Cabinet Maintenance

### **i** NOTE

The following maintenance cycles are for reference only. The actual maintenance cycle should be adjusted according to the natural environment of the equipment location. If the natural environment is severe, the maintenance cycle should be shortened.

### 7.5.1 Tools and Instruments

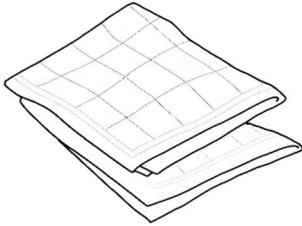
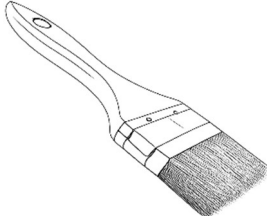
Name	Purpose	Image
Marker Pen and Labels	For recording inspection and maintenance dates.	
Screwdriver and Socket Set	For installation and removal of components.	
Clean Cloth	For wiping dirt.	
Brush	For removing dust.	

Air Blower

For blowing away dust.

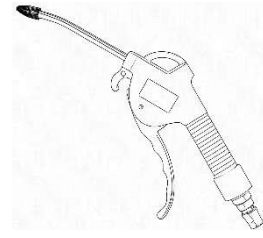

High-Purity

Alcohol/Non-

For removing stubborn dirt.

Corrosive Cleaner



Paint

For repainting the damaged painted surface.



## 7.5.2 Maintenance Items

Item	Frequency	Checklist	Abnormal Condition Handling
		Check for dirt, dust, or foreign objects.	Remove dirt, dust, and foreign objects.
Cabinet Exterior	Every 12 months	Check for any damage to the exterior surface, such as cracks, deformation, fractures, holes, etc.	Repair the damaged exterior surface.
		Check for any component issues, such as missing parts, loose connections, or	Repair or replace components with issues.

		protrusions.	
		Check for dirt, dust, foreign objects, or condensation.	Remove dirt, dust, foreign objects, and condensation.
Cabinet Interior	Every 12 months	Check for any damage to the interior wall lining, floor, and threshold, such as cracks, deformation, fractures, or holes.	Repair the damaged interior wall lining, floor, and threshold.
		Check for any component issues, such as missing parts, loose connections, or protrusions.	Repair or replace components with issues.
Painted Surface	Every 12 months	Check for any damage to the painted surface, such as topcoat peeling or primer damage.	After rust removal, repaint the damaged areas on the painted surface.
Door Lock and Hinges	Every 12 months	Inspect the door lock and hinges for proper function.	Repair or replace malfunctioning door locks and hinges.
Sealing Strip	Every 12 months	Inspect the sealing strip for wear or damage.	Replace damaged sealing strips.

Product	Every 12	Inspect whether the markings	Clean dirty markings and repair or replace damaged ones.
Markings	months	are clear, legible, and free of damage.	

## 7.6 UPS Maintenance

### 7.6.1 Tools and Instruments

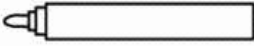
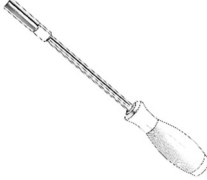
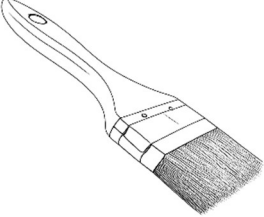
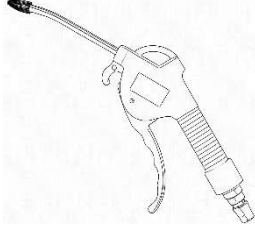
Name	Purpose	Image
Marker Pen and Labels	For recording inspection and maintenance dates.	
Screwdriver and Socket Set	For installation and removal of components.	
Brush	For removing dust.	
Air Blower	For blowing away dust.	

## 7.6.2 Maintenance Requirements

### Equipment Care

For the best preventive maintenance, keep the area around the equipment clean and dust free.

If the atmosphere is very dusty, clean the outside of the system with tools. For full battery life, keep the equipment at an ambient temperature of 25°C.

If the UPS requires any type of transportation, verify that the UPS is disconnected and turned off. The batteries are rated for a 3~5 year service life. The length of service life varies, depending on the frequency of usage and ambient temperature (life divided by 2 each 10°C above 25°C). Batteries used beyond expected service life will often have severely reduced runtimes. Replace batteries at least every 4 years to keep units running at peak efficiency.

### Equipment Storage

If you store the equipment for a long period, recharge the battery every 6 months by connecting the UPS to utility power. The internal batteries charge to 90% capacity in less than 3 hours. It is recommended that the batteries charge for 48 hours after long-term storage.

### Battery Replacement

As shown in the figure below, when the battery replacement screen is displayed, it is recommended to replace the batteries. Battery recommended replacement date can be accessed through the LCD (Measurements > Battery).

Battery Info

Replacement Part No.

UPS Batt: EBP-2406

EBM Batt: EBP-2407 x2



# 8 Troubleshooting

---

## 8.1 Precautions

### **WARNING**

When dealing with a fault, make sure that the device is effectively grounded, otherwise, there may be a risk of electric shock.

### **NOTICE**

- After a fault occurs, it is recommended to keep the initial fault state and log all relevant information about the fault as comprehensively as possible.
- Do not perform non-standard operations. Refer to this chapter for preliminary diagnosis and handling of the fault.
- If the fault remains unresolved or if you have any questions, please contact technical support and after-sales service, and provide logged fault information.

## 8.2 Logging Fault Information

Information Type	Description
Basic Information	Model and serial number of the ESS
	The model number of faulty devices
Operating Status	Pre-fault system parameters (e.g., voltage, current, temperature, SOC, etc.)
Fault Details	Fault type (e.g., abnormal system data display, communication failure)
	Fault occurrence time
	Fault duration
	Operational logs at fault occurrence
Fault Photos	Alarm level and fault code (if applicable)
	Faulty device photos
	Internal component photos (if accessible)
Environmental Information	Alarm interface screenshots (if applicable)
	Ambient temperature and humidity at fault occurrence
	Surrounding influencing factors (e.g., other device failure, external grid fluctuations, extreme weather)

## 8.3 Common Fault Troubleshooting and Solutions

### 8.3.1 Abnormal System Data Display

Fault Description	Causes	Troubleshooting and Solutions
Displayed cell voltage does not match the actual voltage	<ul style="list-style-type: none"> <li>● Voltage acquisition harness loose</li> <li>● Voltage acquisition harness damaged</li> <li>● BMU defective</li> </ul>	<ol style="list-style-type: none"> <li>1. Use a multimeter to measure the actual voltage of the battery cell.</li> <li>2. Replug the voltage acquisition harness connector and check wiring integrity.</li> <li>3. Replace with a new BMU and observe whether the displayed voltage values are accurate.</li> <li>4. Replace the voltage acquisition harness and observe whether the displayed voltage values are accurate.</li> </ol>
Cell voltage fluctuation	<ul style="list-style-type: none"> <li>● Voltage acquisition harness loose</li> <li>● Voltage acquisition harness damaged</li> <li>● Significant on-site interference</li> </ul>	<ol style="list-style-type: none"> <li>1. Replug the voltage acquisition harness connector and check wiring integrity.</li> <li>2. Replace with a new BMU and observe whether the displayed voltage values are accurate.</li> <li>3. Replace the voltage acquisition harness and observe whether the displayed voltage</li> </ol>

	<ul style="list-style-type: none"> <li>● BMU defective</li> </ul>	values are accurate.
Abnormal cell acquisition quantity	<ul style="list-style-type: none"> <li>● Project configuration error</li> <li>● Abnormal acquisition harness</li> <li>● BMU defective</li> </ul>	<ol style="list-style-type: none"> <li>1. Check the project configuration to confirm whether it is normal. If not, modify the relevant configuration.</li> <li>2. Replug the acquisition harness connector and check circuit integrity.</li> <li>3. Replace with a new BMU and observe whether the displayed values are accurate.</li> <li>4. Replace the acquisition harness and observe whether the displayed values are accurate.</li> </ol>
Temperature display shows -40°C or 125°C	<p><b>i Note:</b> -40°C indicates an open circuit, 125°C indicates a short circuit.</p> <ul style="list-style-type: none"> <li>● Thermistor damaged or temperature acquisition harness damaged</li> <li>● BMU defective</li> </ul>	<ol style="list-style-type: none"> <li>1. Replug the temperature acquisition harness connector and inspect wiring integrity.</li> <li>2. Replace with a new BMU and observe whether the displayed values are accurate.</li> <li>3. Replace the temperature acquisition harness and observe whether the displayed values are accurate.</li> </ol>
Abnormal	<ul style="list-style-type: none"> <li>● Project configuration</li> </ul>	<ol style="list-style-type: none"> <li>1. Check the project configuration to confirm</li> </ol>

temperature	error	whether it is normal. If not, modify the
acquisition quantity	<ul style="list-style-type: none"> <li>● Abnormal acquisition</li> </ul>	relevant configuration.
	harness	2. Replug the acquisition harness connector
	<ul style="list-style-type: none"> <li>● BMU defective</li> </ul>	and check circuit integrity.
		3. Replace with a new BMU and observe
		whether the displayed values are accurate.
		4. Replace the acquisition harness and
		observe whether the displayed values are
		accurate.

---

Temperature jumps	<ul style="list-style-type: none"> <li>● External interference</li> </ul>	Replace with a new BMU and observe whether
upward	<ul style="list-style-type: none"> <li>● BMU defective</li> </ul>	the displayed values are accurate.

---

	<ul style="list-style-type: none"> <li>● External interference</li> </ul>	1. Replug the BMU acquisition harness
Temperature jumps	<ul style="list-style-type: none"> <li>● High connector</li> </ul>	connector and observe whether the
downward	impedance	displayed values are accurate.
	<ul style="list-style-type: none"> <li>● BMU defective</li> </ul>	2. Replace with a new BMU and observe
		whether the displayed values are accurate.

---

Abnormal total	<ul style="list-style-type: none"> <li>● Acquisition circuit open</li> </ul>	1. Open the switchgear and perform a fuse
battery voltage	<ul style="list-style-type: none"> <li>● Fuse blown</li> </ul>	continuity test to verify fuse integrity.
acquisition	<ul style="list-style-type: none"> <li>● Incorrect wiring</li> </ul>	2. Inspect acquisition circuit wiring positions

---

	position	for correctness.
	<ul style="list-style-type: none"> <li>● BCU defective</li> </ul>	<ol style="list-style-type: none"> <li>3. Measure acquisition circuit continuity to confirm circuit integrity.</li> <li>4. Replace with a new BCU and observe whether the displayed values are accurate.</li> </ol>
Abnormal total load	<ul style="list-style-type: none"> <li>● Acquisition circuit open</li> <li>● Relay sticking</li> </ul>	<ol style="list-style-type: none"> <li>1. Measure acquisition circuit continuity to confirm circuit integrity.</li> <li>2. Test relay status to check for sticking. Replace it if stuck.</li> </ol>
voltage acquisition	<ul style="list-style-type: none"> <li>● Incorrect wiring position</li> <li>● BCU defective</li> </ul>	<ol style="list-style-type: none"> <li>3. Inspect acquisition circuit wiring positions for correctness.</li> <li>4. Replace with a new BCU and observe whether the displayed values are accurate.</li> </ol>
	<ul style="list-style-type: none"> <li>● Hall sensor power loss</li> </ul>	<ol style="list-style-type: none"> <li>1. Check Hall sensor power supply status.</li> </ol>
	<ul style="list-style-type: none"> <li>● CAN Hall baud rate error</li> </ul>	<ol style="list-style-type: none"> <li>2. Verify CAN Hall baud rate. Correct if abnormal.</li> </ol>
Current is 0	<ul style="list-style-type: none"> <li>● Abnormal communication harness</li> <li>● Incorrect configuration scheme selection</li> </ul>	<ol style="list-style-type: none"> <li>3. Inspect communication harness integrity. Replace if faulty.</li> <li>4. Confirm Hall configuration scheme in settings. Adjust if incorrect.</li> </ol>

Current sensor direction reversed	Incorrect selection of current sensor direction in the configuration	Check whether the Hall configuration scheme in the settings is correct. Adjust configurations if incorrect.
Reproduction of short - board cells	<ul style="list-style-type: none"> <li>The battery cell itself is damaged or has excessive self - discharge.</li> <li>There is a hardware failure in the BMS (Battery Management System).</li> </ul>	<ol style="list-style-type: none"> <li>Check whether the BMS sampling board and the voltage sampling wires inside the PACK are normal.</li> <li>Perform charge - replenishment treatment on the short - board battery cell. If this battery cell remains a short - board one within one month after the charge - replenishment is completed, the PACK needs to be replaced.</li> </ol>

### 8.3.2 Communication Fault

Fault Description	Causes	Troubleshooting and Solutions
BCU-BMU communication abnormality	<ul style="list-style-type: none"> <li>Abnormal communication harness for master-subordinate communication</li> </ul>	<ol style="list-style-type: none"> <li>Inspect the communication harness for integrity. Replace it if abnormal.</li> <li>Verify the baud rate settings in the configuration. Adjust configurations if incorrect.</li> </ol>

	<ul style="list-style-type: none"> <li>● BMU address not assigned</li> </ul>	<ol style="list-style-type: none"> <li>5. Check the address assignment for the BMU. Adjust configurations if incorrect.</li> </ol>
BAU-BCU communication abnormality	<ul style="list-style-type: none"> <li>● Abnormal communication harness</li> <li>● Inconsistent baud rates for BAU-BCU communication</li> <li>● BCU address not assigned or duplicate address</li> <li>● Excessively long bus</li> </ul>	<ol style="list-style-type: none"> <li>1. Inspect the communication harness for integrity. Replace it if abnormal.</li> <li>2. Verify the baud rate settings in the configuration. Adjust configurations if incorrect.</li> <li>3. Check the address assignment for the BCU. Adjust configurations if incorrect.</li> <li>4. Adjust the baud rate and check if BAU-BCU communication is normal.</li> </ol>
BMS-GS/EMS communication abnormality	<ul style="list-style-type: none"> <li>● Communication point list mismatch</li> <li>● Abnormal communication harness</li> <li>● BMS hardware failure</li> <li>● Configuration issues</li> </ul>	<ol style="list-style-type: none"> <li>1. Verify the communication point list used by both BMS and GS/EMS. Correct mapping errors if detected.</li> <li>2. Inspect BMS-GS/EMS communication harness integrity. Replace if faulty.</li> <li>3. Replace with new BMS hardware and observe if communication normalizes.</li> <li>4. Check if point lists and dry contacts exist in the configuration, and verify their settings.</li> </ol>

Modify relevant configurations if incorrectly set.

### 8.3.3 Fire Suppression System Fault

Fault Description	Causes	Troubleshooting and Solutions
The fire alarm control panel displays a system fault	There is a fault in the relevant devices or wiring of the fire protection system.	According to the display on the fire alarm control panel, check whether the corresponding device or wiring is functioning properly. If not, perform repairs or replacements.

### 8.3.4 Liquid Cooling System Fault

#### 8.3.4.1 Fan Fault

Fault Description	Causes	Troubleshooting and Solutions
Condenser fan does not operate	The circuit breaker tripped after being struck by lightning	<p>Check whether there is electricity at the power input of chiller.</p> <p>Check whether the circuit breaker inside the chiller is closed.</p>
	Abnormal power input of	Check whether there are corresponding alarms

chillers (such as over-voltage in the chiller.

or under-voltage)

---

Normal scene. After the chiller is powered on  
The chiller is in standby state and stands by for 30s, it enters the automatic  
control logic.

---

Fan stuck Check whether there is foreign matter stuck in  
the fan.

---

Loose terminal Check whether the wiring terminal of the fan is  
loose.

---

Driver fault Replace the driver.

---

Fan damaged If there is no abnormality in the wiring of the  
condenser fan, and there is no foreign matter  
stuck in the fan, it can be judged that the fan is  
damaged and needs to be replaced.

---

Main control board fault If the above possible causes are ruled out,  
please check whether the main control board is  
faulty.

If yes, please replace it.

---

The fan generates	Wear of fan bearings	Replace the fan.
-------------------	----------------------	------------------

---

abnormal sound	Fan blades scratch other	Check whether cables interfere with fan blades.
----------------	--------------------------	---

---

objects

Fan impeller split	Replace the fan.
--------------------	------------------

### 8.3.4.2 Cooling System Fault

Fault Description	Causes	Troubleshooting and Solutions
Compressor not started	Unpowered (standby)	Check the main power switch, and check whether the chiller has been turned on through the control system operation interface.
	Loose circuit connection	Tighten the circuit connector.
	Open or short circuit	Check the open circuit or short circuit, and repair the main power supply.
	Inverter fault	Replace the inverter.
	Control board damaged	Replace the control board.
	Compressor motor fault	Replace the compressor.
Compressor does not operate	No cooling demand	Check the outlet coolant temperature and the output status of the compressor on the display. Check whether the operating status of the chiller on the display is cooling.
	Shutdown delay	The compressor has the shortest downtime under normal conditions, and if the

temperature rises to the start point during this period, the compressor will still be delayed to open.

### 8.3.4.3 Coolant Circulation System Fault

Fault Description	Causes	Troubleshooting and Solutions
Internal circulating water pump does not start	Unpowered (standby)	Check the main power switch, and check whether the chiller has been turned on through the control system operation interface.
	Loose circuit connection	Tighten the circuit connector.
	Water pump inverter fault	Replace the water pump inverter.
	Pump body fault	Replace the water pump.
Electric heater does not operate	Too low heating set point and no heating demand	Check the outlet coolant temperature, and whether the heating set point is reasonable.
	Loose circuit connection	Tighten the circuit connector.
	Electric heater overheat protection	After waiting for a period of time, restart the electric heater and observe whether the electric heater works normally.
	Electric heater fault	Replace the electric heater.

## 8.3.5 HVAC Fault

### 8.3.5.1 Common Faults

Fault Description	Causes	Troubleshooting and Solutions
	The return air temperature is low, and the unit enters the energy saving mode.	Check whether the fan stop point is set as the cooling point in the operation setting. If yes, the fan will not stop.
Internal cycling fan cannot start	Main power supply failure.	<ul style="list-style-type: none"> <li>● Check if the AC power supply is faulty.</li> <li>● Check if the voltage of the AC power supply is within the rated range.</li> </ul>
	The fan gets stuck.	Check if there is any foreign object that blocks the fan.
	Loose terminal.	Check if the fan connecting terminal is loose.
The fan can run but the control function does not work	The relay does not work.	<ul style="list-style-type: none"> <li>● Check if the relay fails.</li> <li>● Check if the relay coil has AC voltage. If yes, replace the control panel.</li> </ul>
The fan makes abnormal noise	Wear of the fan bearing. The fan blades scrape other objects.	Replace the fan. Check if there are cables or other items interfering with the fan blades.

## 8.3.5.2 Cooling System Fault

Fault Description	Causes	Troubleshooting and Solutions
	The main power supply is not turned on.	Check the main power switch.
The compressor does not start	The compressor is in the standby state.	Check if the compressor is turned on via the operation interface.
	Loose circuit connection.	Tighten the circuit connectors.
	The compressor motor burns out.	Check the motor and replace it if any defect is found.
	There is no cooling demand.	Check the display of the temperature inside the cabinet and the compressor output status on the operation interface.
The compressor does not work	Within shutdown delay.	When the compressor is in normal operation, it has a minimum shutdown time. Even if the temperature rises again to the startup setpoint during this period, the compressor will still delay starting.
	Built-in temperature protection of the compressor.	Check if the relay contact has 220V AC voltage.

	High pressure switch disconnected.	Refer to the <a href="#">High discharge pressure</a> fault in Section 8.3.5.2 Cooling System Fault for troubleshooting steps.
High discharge pressure	The condenser is clogged by dirt.	Clean the condenser.
	The condenser fan does not work.	Check for any fan failure.
	The refrigerant reflows to the compressor.	Check if the air intake unit is over-heated.
Large compressor noise	The bearing is worn out because of the lubricant loss.	Replace the compressor.
	Interference between the compressor and the copper pipe.	Adjust the angle and position of the copper pipe.
	The connecting rod, valve or other rotating gear is broken.	Replace the compressor.
The compressor has intermittent cyclic	Sensor fault.	Check if there is any display of sensor fault alarm.

operation	The system is short of refrigerant.	Check if there is any leakage, repair the leaking part and add refrigerant.
-----------	-------------------------------------	---

The compressor protector trips or work cyclically	High discharge pressure.	<ul style="list-style-type: none"> <li>● Check the clogging state of the condenser filter.</li> <li>● Check if the condenser fan or fan motor is blocked.</li> </ul>
---	--------------------------	--

### 8.3.5.3 Controller Fault

Fault Description	Causes	Troubleshooting and Solutions
Frequent voltage alarm	Power supply failure.	Check the external input power supply.
	Circuit sensor failure.	Replace the circuit board.

### 8.3.6 UPS Fault

#### Review Logs

1. Press the any button on the front panel display to activate the menu options.
2. Press the button to select Event log or Fault log.
3. Scroll through the listed events or faults.

Fault Description	Causes	Troubleshooting and Solutions
Battery mode	A utility failure has occurred	The UPS is powering the equipment with



LED is On.

1 beep every 10 seconds.

and the UPS is in Battery mode.

battery power. Prepare your equipment for shutdown.

Battery mode



LED is On.

1 beep every 3 seconds.

The UPS is in Battery mode and the battery is running low.

This warning is for an approximate time, and the actual shutdown time may vary significantly.

Depending on the UPS load and number of Extended Battery Modules (EBMs), the "Battery Low" warning may occur before the batteries reach 20% capacity.

No battery



LED is On.

Beep continuously.

The batteries are disconnected.

Verify that all batteries are properly connected. If the condition persists, please contact the after-sales service. For contact information, refer to [Chapter 9 Technical Support and After-Sales Service](#).

Battery mode





LED is On.

Beep continuously.

Battery failure or disconnection caused the battery test to fail.

Verify that all batteries are properly connected. If the condition persists, please contact the after-sales service. For contact information, refer to [9 Technical Support and After-Sales](#)

		<u>Service.</u>
UPS does not provide the expected backup time	The batteries need charging or service.	Apply utility power for 48 hours to charge the batteries. If the condition persists, please contact the after-sales service. For contact information, refer to <a href="#">9 Technical Support and After-Sales Service.</a>
Battery overload  LED is On.	Power requirements exceed the UPS capacity (greater than 100% of nominal).	Remove some of the equipment from the UPS. The UPS continues to operate, but may switch to Bypass mode or shut down if the load increases. The alarm resets when the condition becomes inactive.
UPS overtemperature  LED is On. 1 beep every 3 seconds.	The UPS internal temperature is too high or a fan has failed. At the warning level, the UPS generates the alarm but remains in the current operating state.	Clear vents and remove any heat sources. Allow the UPS to cool. Ensure the airflow around the UPS is not restricted. Restart the UPS. If the condition persists, please contact the after-sales service. For contact information, refer to <a href="#">9 Technical Support and After-Sales Service.</a>

If the temperature rises another 10°C, the UPS will shut down.

The input source is not connected correctly. Check the input and battery connections.

UPS does not start The Remote Power Off (RPO) switch is active or the RPO connector is missing. If the UPS Status menu displays the "Remote Power Off" notice, inactivate the RPO input.

### 8.3.7 Other Faults

Fault Description	Causes	Troubleshooting and Solutions
Insulation withstand fault	Conduct simultaneous insulation withstand tests on the PCS and BMS	<p>Verify if PCS insulation withstand test is active.</p> <p>Disconnect PCS and check if a fault is triggered.</p> <p>Revise the insulation withstand detection in the configuration.</p>
Relay Abnormality	<ul style="list-style-type: none"> <li>Abnormal relay feedback wiring harness</li> <li>Relay sticking</li> </ul>	<ol style="list-style-type: none"> <li>Inspect the relay feedback wiring harness integrity. Replace if faulty.</li> <li>Test relay status to check for sticking. Replace it if stuck.</li> </ol>
Access control fault	<ul style="list-style-type: none"> <li>Display reversed</li> </ul>	<ol style="list-style-type: none"> <li>Check access control wiring integrity. Take</li> </ol>

- No response relevant actions if abnormal.
  - Configuration not written  
2. Verify configuration settings. Modify incorrect configurations.
  - Access control damaged  
3. Replace the access control and observe if it works normally.
-

## 9 Technical Support and After-Sales Service

---

SYL (Ningbo) Battery Co., Ltd. has always adhered to the "Customer First" service philosophy, establishing a full product lifecycle service system. On technical support, the company is supported by a senior engineer team providing end-to-end support from pre-sales consultation to after-sales service. Backed by 23 global service centers, it achieves 24/7 rapid response, delivering comprehensive technical support and efficient after-sales service to customers worldwide.

### Contact Information

**After-sales Hotline** +86 400-101-8585

**After-sales Email** [service@sybattery.com](mailto:service@sybattery.com)

### Warranty

SYL (Ningbo) Battery Co., Ltd. provides warranty services for its products. The duration and specific terms of free warranty coverage shall be exclusively governed by the signed contract clauses.

To protect your rights and clarify service scope, the following scenarios are explicitly

excluded from free warranty coverage, and SYL shall not be liable for them:

## **Improper Operation**

- System damage or failure caused by not following the operating instructions and safety precautions in the user manual.
- System damage or failure due to unauthorized disassembly, modification of the product, or alteration of software code by the user.
- Damage or failure to system hardware caused by user negligence, improper operation, or intentional damage.
- System damage caused by third parties or users, including handling and installation not in line with manual requirements, and unauthorized adjustments, modifications, or removal of identification marks.
- After a system failure, the user fails to promptly contact technical support and after-sales service, and performs unauthorized operations, leading to a loss of fault-related information and hindering effective fault identification and resolution.

## **Improper Use**

- Functional abnormalities, component damage, personal injury, or property damage caused by using the system in an environment that does not meet the design requirements.
- System damage or failure due to non-compliance with relevant electrical safety regulations for wiring and power supply.

- Installation and usage environments that do not conform to regulations stipulated in relevant international, national, or regional standards.
- System damage or failure caused by battery usage that does not satisfy the requirements of this manual.
- System damage or failure caused by storage conditions that do not meet the requirements of this manual.
- System damage or failure caused by force majeure natural factors, such as typhoons, earthquakes, floods, fires, mudslides, or adverse environmental conditions like high temperatures, low temperatures, high humidity, and acid rain.

## Feedback

If you have any comments or suggestions regarding this manual, please share them with us via email. Your feedback is highly valued as it enables us to constantly enhance the manual's quality, ensuring that we deliver more excellent content and a superior user experience.

## Abbreviations

Abbreviations	Full Term
AC	Alternating Current
Ah	Ampere-hour
AHJ	Authority Having Jurisdiction
BAU	Battery Array Management Unit
BCP	Battery Connection Panel
BCU	Battery Cluster Management Unit
BESS	Battery Energy Storage System
BMS	Battery Management System
BMU	Battery Module Management Unit
BOS	Balance of System
BTMS	Battery Thermal Management System
CAN	Controller Area Network
CCU	Communication Control Unit

DC	Direct Current
EMS	Energy Management System
FSS	Fire Suppression System
GS	Golden Shield
HMI	Human Machine Interface
HVAC	Heating, Ventilation, and Air Conditioning
IP	Ingress Protection
kV	Kilovolt
kW	Kilowatt
LFP	Lithium Iron Phosphate
LSI	Large-Scale Integration
MCB	Miniature Circuit Breaker
MCCB	Molded Case Circuit Breaker
MSD	Manual Service Disconnect
MW	Megawatt
MWh	Megawatt-hour
PCB	Printed Circuit Board
PCS	Power Conversion System
PLC	Programmable Logic Controller
SCADA	Supervisory Control and Data Acquisition

SMPS	Switch Mode Power Supply
SOC	State of Charge
SPD	Surge Protective Device
UPS	Uninterruptible Power Supply

## Fastening Torque

Bolt	Recommended Torque (N•m)	Torque Range (N•m)
M4	2.59	2.38~2.80
M5	5.18	4.76~5.60
M6	9.07	8.33~9.80
M8	22.67	20.83~24.50
M10	40.80	37.49~44.10
M12	72.62	66.73~78.50
M16	138.75	127.50~150.00

### **i** Notes:

- The recommended torque values and torque ranges listed above apply only to fasteners with a property class of 8.8 and not to fasteners of other property classes.
- The torque values listed above are for reference only. Please adjust them according to actual conditions.



## **SYL (Ningbo) Battery Co., Ltd.**

**Address** Risen Energy Meiqiao Phase I, Ninghai County, Ningbo City, Zhejiang Province

**Tel** +86 400-101-8585

**Website** [www.risenstorage.com](http://www.risenstorage.com)

